

# NITRO BLAST

**1/10 SCALE NITRO POWERED STADIUM TRUCK**

**4WD**

***Instruction manual • Bouwhandleiding • Bauanleitung • Instructions de montage***



## **SAS: Service after sales**

Please note that only manufacturing faults or problems caused by manufacturer faults will be repaired on the account of SAS. It is not possible to claim warranty if the problem is caused by misuse of this product.

### **SAV INTERNATIONALE PROTECH**

TEL: ++ 32 14 25 92 83

FAX: ++ 32 14 25 92 89

email: [info@promodels.be](mailto:info@promodels.be)

<http://www.protech.be>

Please use the spare parts list at the back of this manual to help you find the part more easily

PROTECH cannot be held responsible for damage or any claims arising from the use of this product.

## **SNV: Service na verkoop**

Alléén fabricagefouten of problemen veroorzaakt door een fabricagefout zullen op rekening van de SNV hersteld worden. Er kan nooit aanspraak gemaakt worden op een gratis herstelling door de SNV als de problemen voortkomen uit een verkeerd gebruik van het produkt

### **SAV INTERNATIONALE PROTECH**

TEL: ++ 32 14 25 92 83

FAX: ++ 32 14 25 92 89

email: [info@promodels.be](mailto:info@promodels.be)

<http://www.protech.be>

Om het zoeken van het onderdeel dat u nodig hebt te vergemakkelijken, gelieve de onderdelenlijst op pagina 25-26 van deze handleiding te raadplegen

PROTECH kan niet verantwoordelijk gesteld worden voor schade of vorderingen voortvloeiend uit het gebruik van dit produkt

## **KD : Kundendienst**

Nur Herstellungsfehler oder durch Herstellungsfehler verursachte Probleme werden für Rechnung des KD repariert. Die Garantie kann nicht in Anspruch genommen werden, wenn das Problem auf eine unsachgemäße Verwendung des Erzeugnisses zurückzuführen ist.

### **SAV INTERNATIONALE PROTECH**

TEL: ++ 32 14 25 92 83

FAX: ++ 32 14 25 92 89

email: [info@promodels.be](mailto:info@promodels.be)

<http://www.protech.be>

Bitte verwenden Sie die in diesem Anweisungsheft auf Seite 25-26 abgedruckten Diagramme, um die Ersatzteile zu finden, die Sie benötigen.

PROTECH kann nicht für Schäden oder Ansprüche haftbar gemacht werden, die sich aus der Verwendung dieses Produkts ergeben.

## **SAV: Service après vente**

Ne seront pris en charge par le SAV, que les pièces présentant un vice de fabrication. En aucun cas, la mauvaise utilisation du produit ne peut engendrer un SAV gratuit.

### **SAV INTERNATIONALE PROTECH**

TEL: ++ 32 14 25 92 83

FAX: ++ 32 14 25 92 89

email: [info@promodels.be](mailto:info@promodels.be)

<http://www.protech.be>

Afin de faciliter la recherche de vos pièces détachées, veuillez consulter la liste des pièces détachées en fin de cette notice

PROTECH ne peut pas être rendu responsable pour des dommages provenant de l'utilisation de ce produit.

# OUT OF THE BOX

1

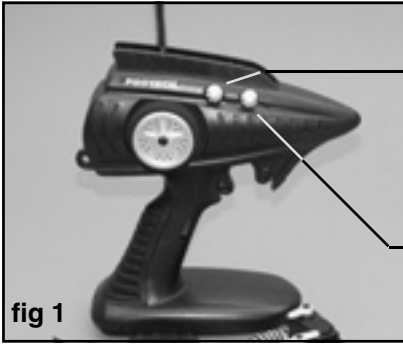

Steering trim

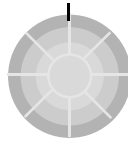
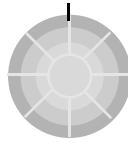

Throttle trim

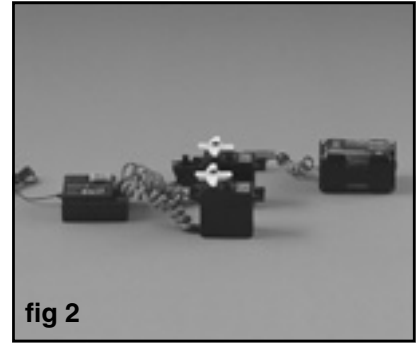

Place the batteries in the transmitter.  
Place the batteries in the battery holder for the receiver.  
Plug the battery holder into the slot on the receiver marked "BATT". Plug your steering servo into channel 1 and your throttle servo into channel 2. Check that your servos move when you move the sticks on the transmitter, next set the trims on the transmitter to the neutral position as shown in fig 1.

*Plaats de batterijen in de radiobesturing.  
Plaats de batterijen in de batterijhouder. Sluit de batterijhouder, de gas- en stuurservo aan op de ontvanger. Schakel de radiobesturing en de ontvanger aan. Plaats de stuurhendels en de stuurtrims van de radiobesturing in de middelste positie. De stuurarmen van de beide servo's moeten nu neutraal staan.*

Placez les piles dans la radio-commande.  
Placez les piles dans le boîtier-piles du récepteur. Raccordez le boîtier-piles, les servos de gas et de direction au récepteur. Mettez la radio-commande et le récepteur en marche. Placez les manettes et les trims en position neutre. Les leviers de commande des deux servos doivent maintenant se trouver en position neutre.

*Setzen Sie die Batterien in den Sender. Setzen Sie die für den Empfänger bestimmten Batterien in den Batteriehalter. Stecken Sie den Batteriehalter in den mit „BATT“ gekennzeichneten Schlitz auf dem Empfänger. Stecken Sie Ihr Steuerservogerät in Kanal 1 und Ihr Drosselklap-penservogerät in Kanal 2. Prüfen Sie, ob Ihre Servogeräte sich bewegen, wenn Sie die Hebel auf dem Sender bewegen, und stellen Sie die Trimme auf dem Sender anschließend in die neutrale Position, so wie es Abb. 1 zu entnehmen ist.*

2

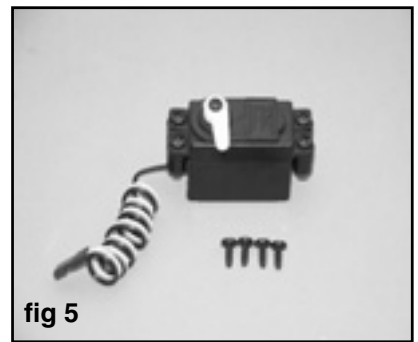
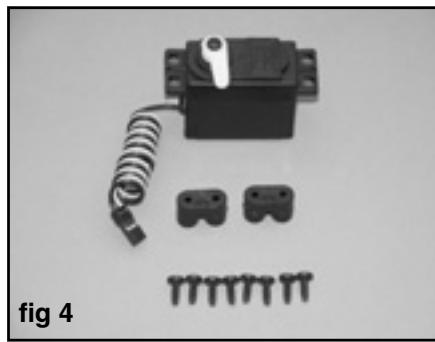

Disassemble the radio tray as shown in fig 3.  
The mounting for the steering servo uses 2 plastic blocks.  
Fix the steering servo to the plastic blocks using the two 3X8mm selftappers supplied. See fig 4,5.

*Demonteer de radio-plaat. Voor de bevestiging van de stuurservo gebruiken we de plastic steunen zoals afgebeeld.  
Bevestig de plastic steunen zoals afgebeeld met de 3 X 8 mm zelftap schroeven.*

Demontez la platine radio.  
Pour fixer le servo de direction, utilisez les supports en plastique comme le montre l'illustration. fixez les supports en plastique comme représenté avec les vis auto-taraudeuses 3 x 8 mm.

*Nehmen Sie die Nylon R/C Platte auseinander Abb.3. Montieren Sie das Steuerservogerät mit den beiden mitgelieferten 3 x 8 mm-Selbstbohrern gemäß an den Plastikklötzen unter den Funkgeräteinsatz. Siehe Abb. 4-5.*

## OUT OF THE BOX

3

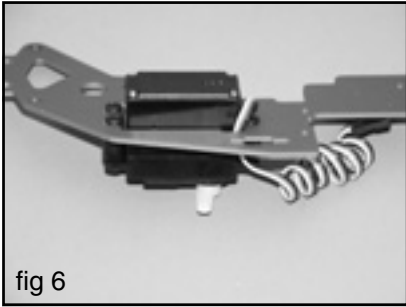

fig 6

Mount the steering servo upside down in the radio tray, using the 3x 8mm self-tappers as shown in

*Monteer de stuurservo op de radioplaat zoals afgebeeld. Gebruik hiervoor de zelftap schroeven 3 x 8 mm.*

Montez le servo de direction sur la platine radio comme le montre l'illustration. Utilisez pour cela les vis auto-taraudeuses 3 x 8 mm.

*Befestigen Sie das Steuerservogerät Oberseite unten, unter Verwendung der beiden mitgelieferten 3 x 8mm Selbstbohrer,*

4

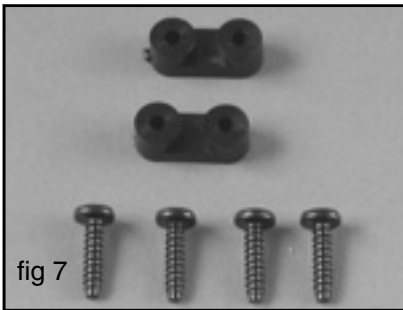

fig 7



fig 8

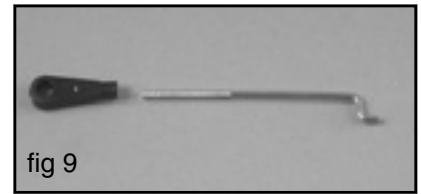

fig 9

Mount the throttle servo into the radio tray as shown in fig 8. Use parts as shown in fig 7.

Make the steering rod using parts shown in fig 9. (Adjust the length of this rod to make your car drive straight)

*Monteer de gasservo op de radioplaat zoals afgebeeld. Gebruik hiervoor de zelftap schroeven 3 x 12 mm en de plasticblokjees zoals afgebeeld.*

*Monteer de stuurstang zoals afgebeeld. (Pas de lengte aan zodat uw auto recht door rijdt)*

Montez le servo de gas sur la platine radio comme le montre l'illustration. Utilisez pour cela les vis auto-taraudeuses 3 x 12 mm ainsi que les petits blocs en plastique.

Montez la tringle de commande comme le montre l'illustration.

*Befestigen Sie das Servo in die R/C Platte, Abb. 8. Verwenden Sie die Teile gezeigt in Abb. 7.*

*Befestigen Sie die Lenkstangen gemäß Abb. 9 am Servogerätschutz. (Justieren Sie die Länge dieser Stange, damit Ihr auto gerade Fahrt)*

5

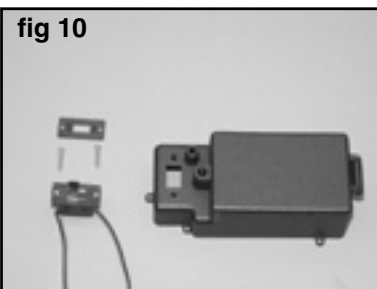

fig 10

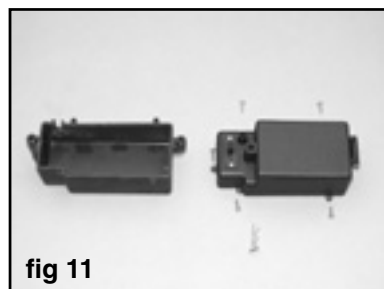

fig 11



fig 12

Install the switch into the Rx box and assemble the Rx box. See fig. 10-11-12.

*Installeer de schakelaar in de doos en monteer deze. Zie fig. 10-11-12.*

Installez l'interrupteur sur le boîtier, et assemblez-le. Voir fig 10-11-12.

*Installieren Sie den Schalter in die RC-Box und montieren Sie die RC-Box. Fig. 10-11-12.*

6

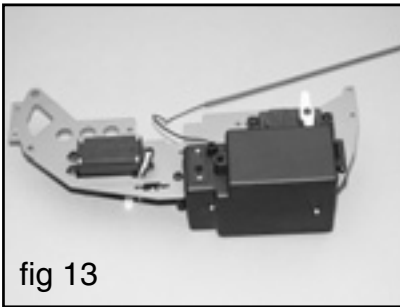

fig 13

Mount the Rx box to the radio tray.

Pull the antenna out of the Rx box and push it through the antenna tube (you can use a little bit of silicon oil to make it easier). Put the antenna tube into the Rx box.

Mount the steering rod on the servo.

Mount the radio tray back onto the chassis, connect the steering rod onto the ball of the servo-saver.

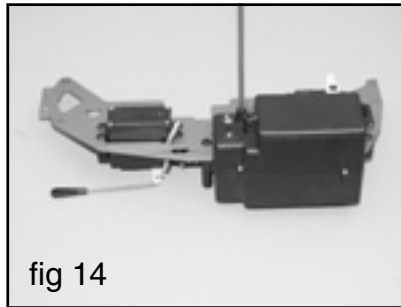

fig 14

*Monteer de ontvangerdoos op de radioplaat.*

*Steek de antenne door het gaatje en daarna door de antennebuis. Monteer de antennebuis op de ontvangerdoos.*

*Monteer de stuurstang op de servo.*

*Monteer de stuurstang op het bolgewricht van de servo-saver.*

Montez le boîtier sur la platine radio.

Faites sortir le fil d'antenne du boîtier et introduisez-le dans tube d'antenne. Fixez-le sur le boîtier.

Montez la tige de commande sur le servo.

Remontez la platine sur le véhicule et connectez la barre de direction au sauto-servo.

*Montieren Sie die RC-Box auf die Radio-platte.*

*Führen Sie die Antenne durch das Loch und Antennerohr. Befestigen Sie das Antennerohr auf die RC-Box.*

*Befestigen Sie das Lenkgestänge auf dem Servo.*

*Befestigen Sie das Lenkgestänge mit den Ballverbindungen auf den servo-saver.*

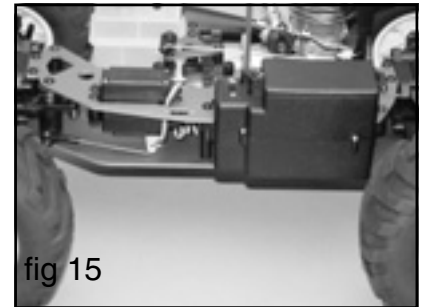
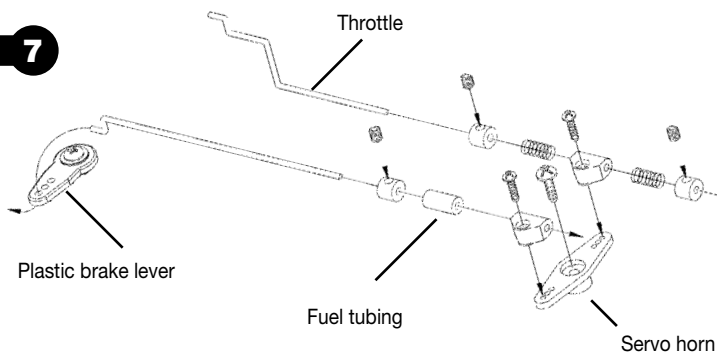

fig 15

7



Use the parts supplied for the throttle and brake linkage .

Mount the throttle and brake linkage as shown above.

Make sure that the throttle stick is in the neutral position and the trim is in the center, when your throttle linkage is adjusted correctly, your carburetor should be open 1-2mm and the brake should not be engaged. When the stick is pushed forwards the carburetor should open completely, when you pull back the stick the brake should engage.

*Onderdelen die nodig zijn voor de aansturing van de carburator en de rem.*

*Monteer de gas en remaansturing zoals afgebeeld. Als de servo neutraal staat moet de carburator een klein beetje openstaan. Als de knuppel van het gas naar voor gedruwd wordt moet de carburator volledig opengaan. Als de knuppel naar achteren getrokken wordt moet de rem werken.*

Utilisez les pièces nécessaires à la commande du carburateur et du frein.

Montez la commande d'accélération et de freinage comme représenté sur l'illustration. Si le servo se trouve en position neutre, le carburateur doit être un petit peu ouvert. Si la manette d'accélération est poussée vers l'avant, le carburateur doit s'ouvrir complètement. Si la manette est tirée vers l'arrière, le frein doit fonctionner.

*Für die Verbindung von Drosselklappe und Bremse benötigte Teile.*

*Montieren Sie die Verbindung zwischen Drosselklappe und Bremse. Stellen Sie sicher, dass der Drosselklappenhebel sich in der neutralen Position befindet. Wenn Ihre Drosselklappenverbindung richtig eingestellt ist, muss Ihr Vergaser 1- 2 mm geöffnet sein, und die Bremse darf nicht angezogen sein. Wenn der Hebel nach vorn gedrückt wird, muss sich der Vergaser vollständig öffnen. Wenn Sie den Hebel nach hinten ziehen, muss die Bremse angezogen werden.*

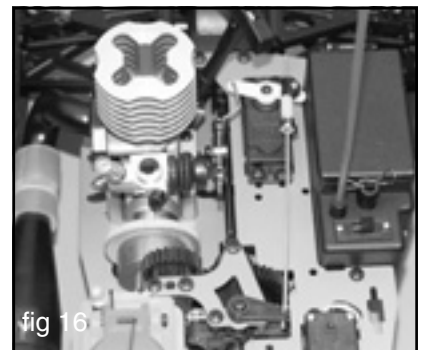

fig 16

# OUT OF THE BOX

9



Mount the air-filter as shown. We recommend using an air filter oil to protect your engine (PROTECH LX906)

*Monteer het luchtfilter. Wij raden aan om speciale luchtfilterolie (PROTECH LX906) te gebruiken.*

Installez le filtre à air. Nous recommandons d'utiliser de l'huile spéciale pour filtre à air. (PROTECH LX906)

*Montieren Sie den Luftfilter. Wir empfehlen (PROTECH LX906) Luftfilter-Öl für eine gute Wirkung.*

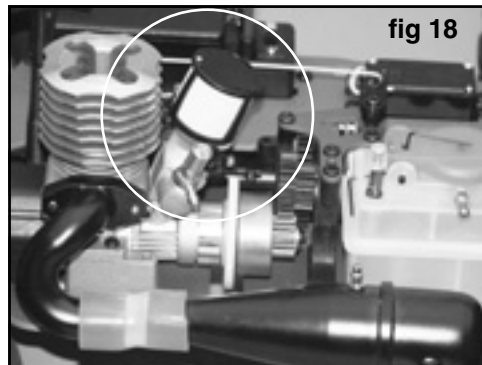

10

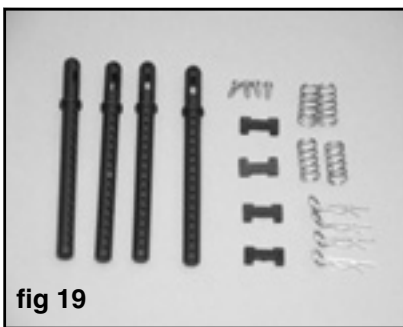

Mount the body mounting post's onto the chassis as shown. Use the 2x 5mm self tappers supplied.

*Monteer de carrosserie-steunen in de houder en fixeer ze met de 2 x 5 mm vijzen.*

Montez les fixations de carrosserie dans leurs supports et fixez-les avec les vis auto-taraudeuses de 2 x 5 mm.

*Die Karosseriemontagestützen werden mit den mitgelieferten 2 x 5 mm-Selbstbohrern zusammengeschraubt.*

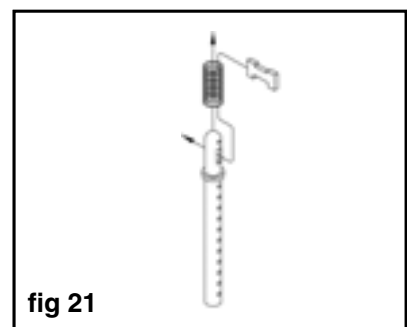
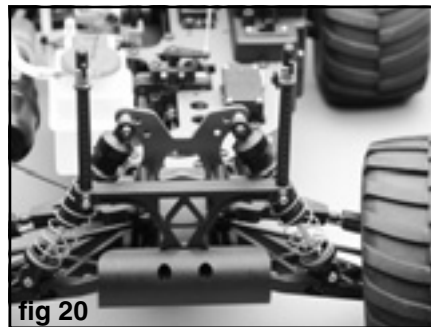

11

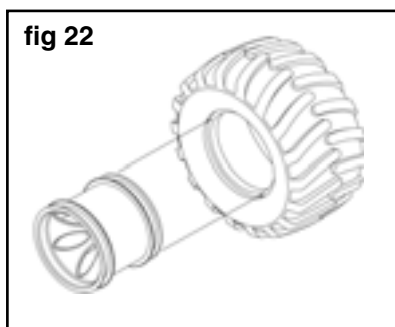

Mount the tires on the rims, carefully glue the tires to the rims using super glue (we recommend using PROTECH CA glue part no: A105 -25) Once the tires are glued place the rims onto the car and secure with M4 lock-nuts.

*Monteer de banden op de velgen. Lijm de banden vast met Sekundenlijm. Monteer vervolgens de wielen aan het chassis. Schroef de wielen vast met M4 stopmoeren.*

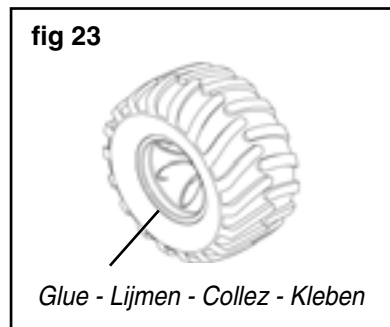

Montez les pneus sur les jantes. Collez fermement les pneus avec de la colle cyanoacrylate. Montez ensuite les roues sur le châssis. Vissez fermement les roues au moyen d'écrous nylstop M4.

*Montieren Sie die Reifen auf die Felgen. Kleben Sie die Reifen vorsichtig mit Sekundenkleber (Teil Nr. A105-25) an die Felgen. Sobald der Klebstoff trocken ist, können Sie die Räder an das Auto montieren. Werden von M4-Muttern gehalten.*

**PROTECH**

## OUT OF THE BOX

12

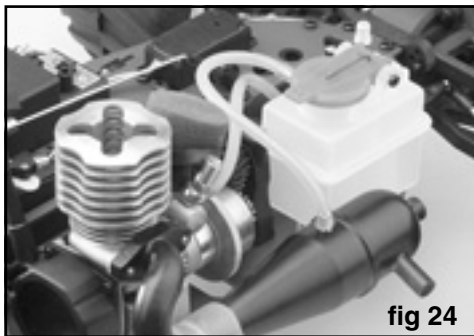

fig 24

On the tank you will find two brass nipple's, there is one at the bottom of the tank, connect this too the carburator.

The other one is on top of the tank, connect this one to the pressure nipple on the exhaust pipe

*Sluit de silicone brandstofslangen aan. Er wordt een brandstofslang aan de onderste tanknippel aangesloten, deze vertrekt vervolgens naar de aansluitnippel van de carburator. De volgende brandstofslang wordt aan de druknippel van de tank aangesloten (deze bevindt zich aan de tankdop), deze vertrekt naar de aansluitnippel van de uitlaat.*

Raccordez les durites en silicone.

Une durite à carburant est raccordée à la prise inférieure du réservoir et part ensuite vers la prise du carburateur. La durite suivante est raccordée à la prise supérieure du réservoir et part ensuite vers la prise de pressurisation sur l'échappement.

*Schließen Sie den mitgelieferten Silikontreibstoff-Rohrstrang an den Treibstoffnippel unter dem Tank und an den Treibstoffeinlass-nippel des Vergasers an. Der nächste anzuschließende Treibstoffrohrstrang reicht vom Nippel oben auf dem Treibstofftank zum Auspuffdrucknippel.*

## Decals

13



**PROTECH**

# OUT OF THE BOX

## **Mounting the body**

Cut out the polycarbonate body using a pair of curved lexan scissors. These special lexan scissors are available from all good model shops (AK100). When cutting, follow the bottom line on the body. Then cut out the front wheel openings. When the body is cut out place it onto the chassis and center it over the chassis. Once the body is centered on the chassis, mark the position of the body mounting posts with a marker pen. Drill holes the same diameter as the bodyposts, and cut out.

## **Painting the body**

The body is painted or sprayed on the inside. For this use only special paint that is suitable for polycarbonate. (We recommend PROTECH RACING FINISH) Before starting to paint or spray, the body must be thoroughly degreased. This can be done by washing the inside of the body with water and soap or washing up liquid. Use a normal towel to dry the body, do not use paper towels to do this as they cause static electricity to build up inside the body and this will attract dust. When the body is dry, try not to touch the inside of the body. The following step is to mask off the windows with masking tape/film or masking liquid. When spraying the body, use very light coats and allow to dry between coats.

---

## **Montage van de carrosserie**

*Knip de polycarbonaat carrosserie uit d.m.v. een speciale lexanschaar. Deze lexanschaar is te verkrijgen bij uw modelbouwvakhandelaar. (Best nr AK100). Volg voor het uitknippen de onderste lijn die in de carrosserie afgetekend staat. Knip vervolgens de voorste wielrondingen uit. Plaats de uitgesneden carrosserie op het chassis en centreer de carrosserie op het chassis. Als de carrosserie mooi uitgelijnd is, teken vervolgens de plaats van de bodysteunen af d.m.v. een stift of pen. Boor gaten op de afgetekende plaatsen. De diameter van de gaten is afhankelijk van de diameter van de carrosseriesteun.*

## **Schilderen van de carrosserie**

*De carrosserie wordt aan de binnenkant geschilderd met penseel of gespoten. Gebruik hiervoor enkel speciale verf geschikt voor polycarbonaat (b.v. Lexanit). Alvorens met het schilderen of spuiten te beginnen moet de carrosserie goed ontvet worden. De carrosserie kan eenvoudig ontvet worden met water en detergent voor de afwas. Daarna goed afdrogen. Gebruik hiervoor geen papieren doekjes, zij maken de carrosserie statisch. Een gewone keukenhanddoek is perfect.*

---

## **Montage de la carrosserie**

Découpez la carrosserie en polycarbonate au moyen de ciseaux spéciaux pour Lexan. Ces ciseaux pour Lexan sont disponibles chez votre détaillant en modélisme. (réf:AK100). Pour le découpage, suivez la ligne inférieure qui est dessinée dans la carrosserie. Découpez ensuite les passages des roues avant. Placez la carrosserie découpée sur le châssis et centrez-la. Lorsque la carrosserie est correctement alignée, tracez l'emplacement des supports de carrosserie au moyen d'un crayon ou d'un stylo à bille. Forez les trous aux emplacements que vous avez marqués. Le diamètre des trous dépend du diamètre du support de la carrosserie.

## **Peinture de la carrosserie**

La carrosserie est peinte au pinceau, à l'aérographe ou au spray, du côté intérieur. Utilisez pour cela uniquement de la peinture spéciale convenant au polycarbonate (par ex. Lexanit). Avant de commencer à peindre, la carrosserie doit être bien dégraissée. Elle peut être simplement dégraissée avec de l'eau et du détergent vaisselle. Ensuite, séchez soigneusement. N'utilisez pas de mouchoirs en papier qui chargent la carrosserie en électricité statique. Un essuie de cuisine ordinaire convient parfaitement.

---

## **Montage der Karosserie**

*Schneiden Sie die Polycarbonat-Karosserie mit einer gebogenen Lexan-Schere aus. Diese speziellen Lexan-Scheren sind in allen guten Modellgeschäften erhältlich (AK100). Folgen Sie beim Schneiden der unteren Linie der Karosserie. Schneiden Sie dann die Vorderradöffnungen aus. Schneiden Sie die Hinterräder noch nicht aus. Wenn die Karosserie ausgeschnitten ist, setzen Sie sie auf das Chassis, und zentrieren Sie sie über dem Chassis. Sobald die Karosserie auf dem Chassis zentriert ist, markieren Sie die Position der Karosserie-Montagestützen mit einem Markierstift. Bohren Sie Löcher, die denselben Durchmesser haben wie die Karosseriestützen. Sobald alle Löcher gebohrt sind, setzen Sie die Karosserie auf das Chassis, markieren Sie die Position der Hinterräder, und schneiden Sie aus.*

## **Anstrich von Karosserie und Kotflügel**

*Die Karosserie wird innen lackiert oder gesprüht. Verwenden Sie hierfür nur Spezialfarbe, die für Polycarbonat geeignet ist. (Wir empfehlen PROTECH RACING FINISH). Vor Beginn des Anstrich- oder Sprühvorgangs muss die Karosserie sorgfältig entfettet werden. Dies kann durch Reinigung des Wageninneren mit Wasser und Geschirrspülmittel erfolgen. Verwenden Sie zum Abtrocknen der Karosserie ein normales Handtuch. Verwenden Sie keine Papierhandtücher, da sie zum Aufbau statischer Elektrizität im Wageninnern führen würden, was Staub anzieht. Wenn die Karosserie trocken ist, versuchen Sie, das Wageninnere nicht zu berühren. Der folgende Schritt besteht im Abdecken der Fenster mit Abdeckband/film oder Abdeckflüssigkeit. Wenn Sie die Karosserie sprühen, verwenden Sie sehr dünne Schichten, und lassen Sie die Karosserie zwischen den Schichten trocknen.*



# TECHNICAL PLAN

1

**Differential gear set**  
Ensemble de pignons de différentiel  
Differentieel tandwiel set  
Kegelzahnrad Satz  
T0600.005 (set)

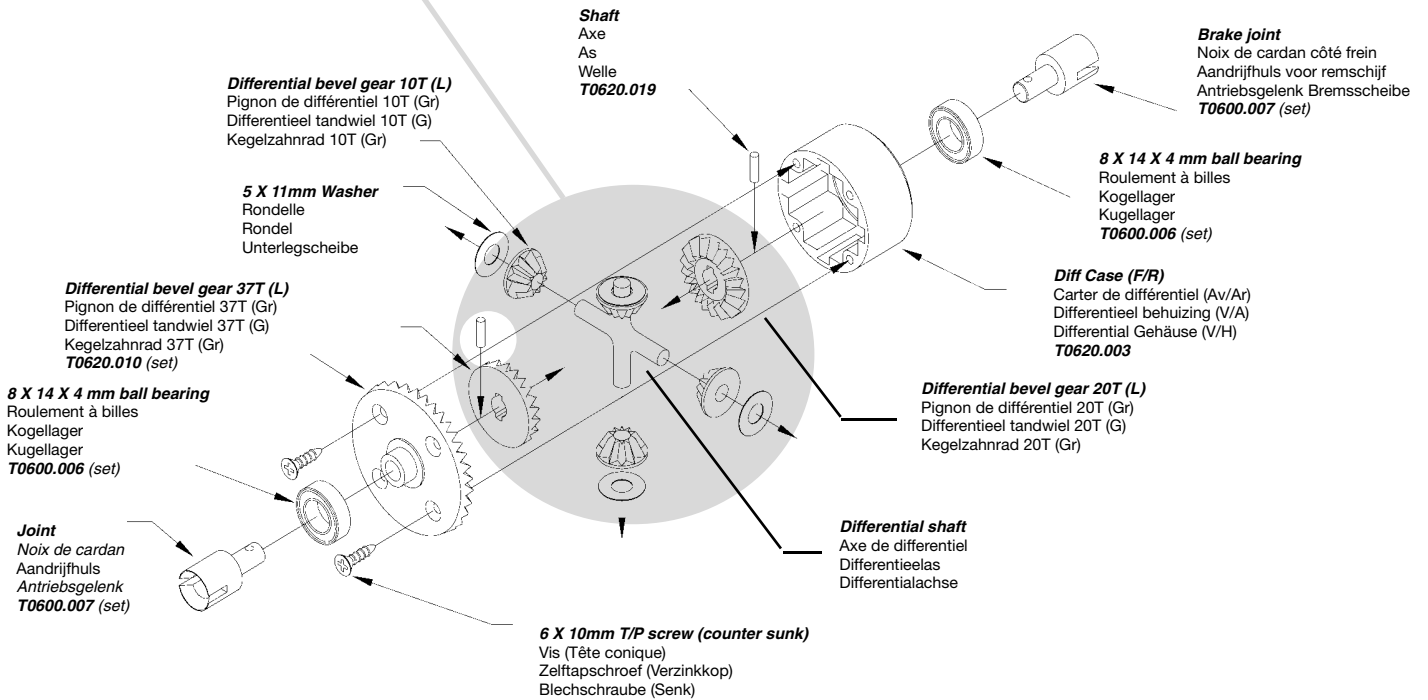

2

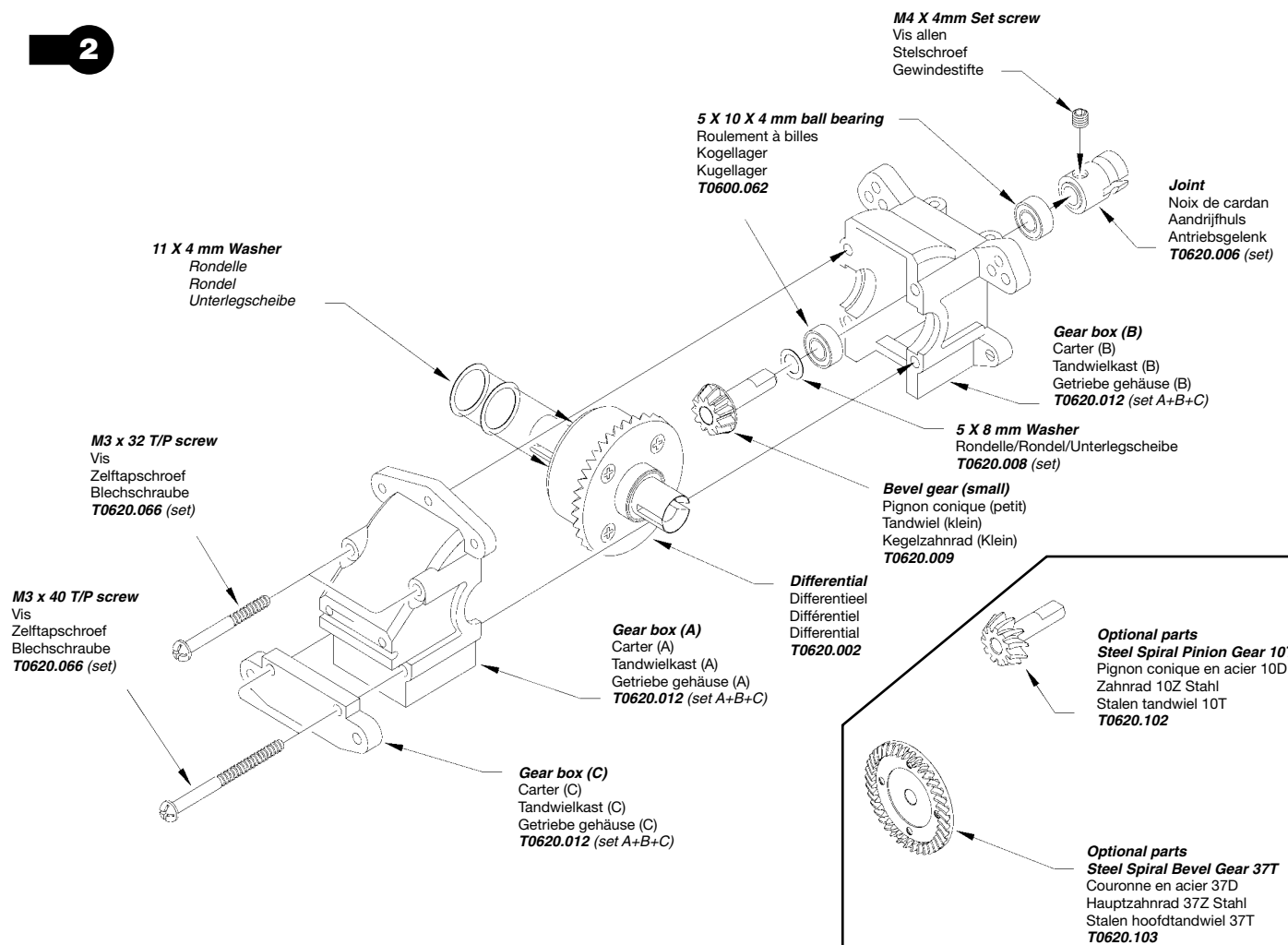

# TECHNICAL PLAN

3

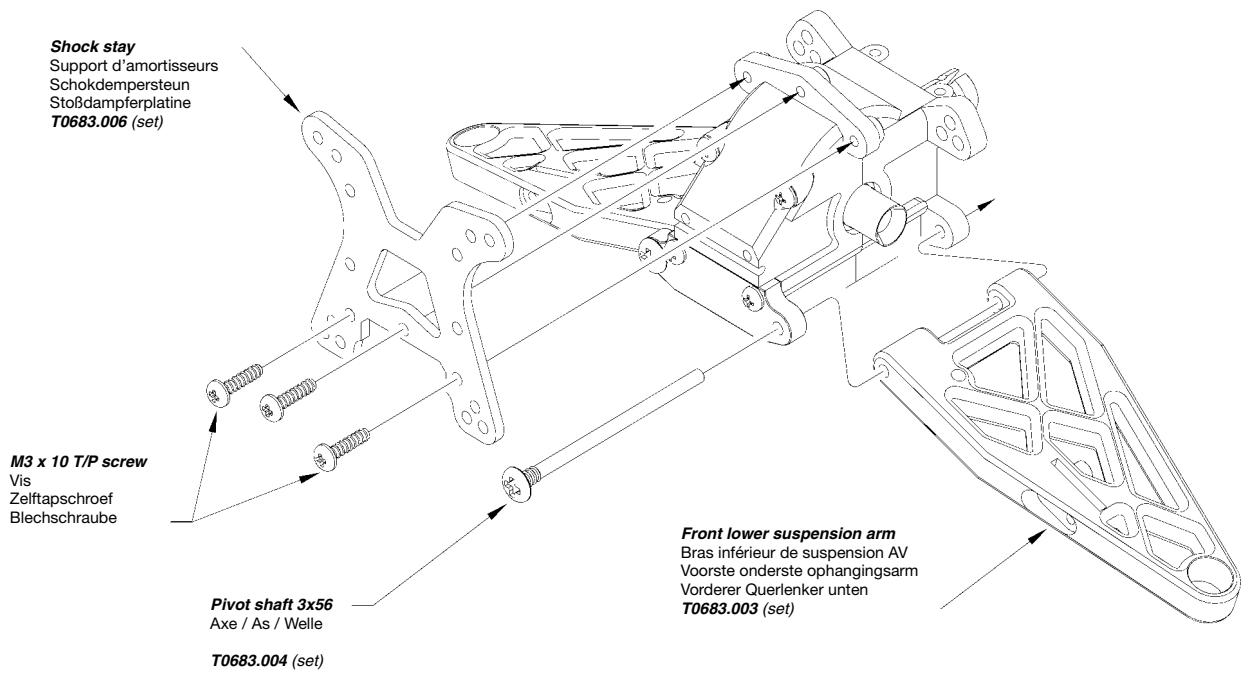

4

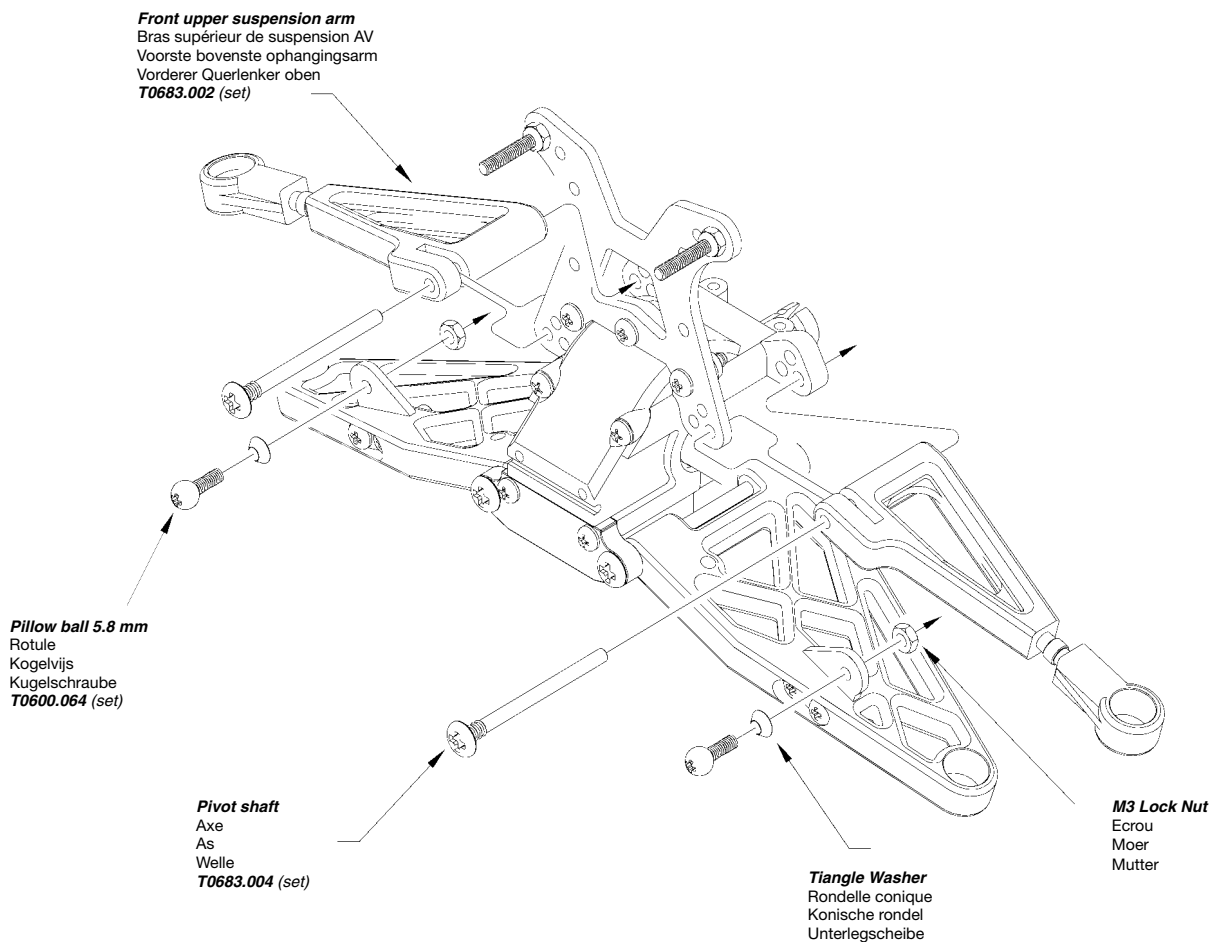

# TECHNICAL PLAN

5

**CVA Joint 115 mm**  
Cardan homocinétique  
Steekas  
Antriebswellen  
T0683.019 (set)

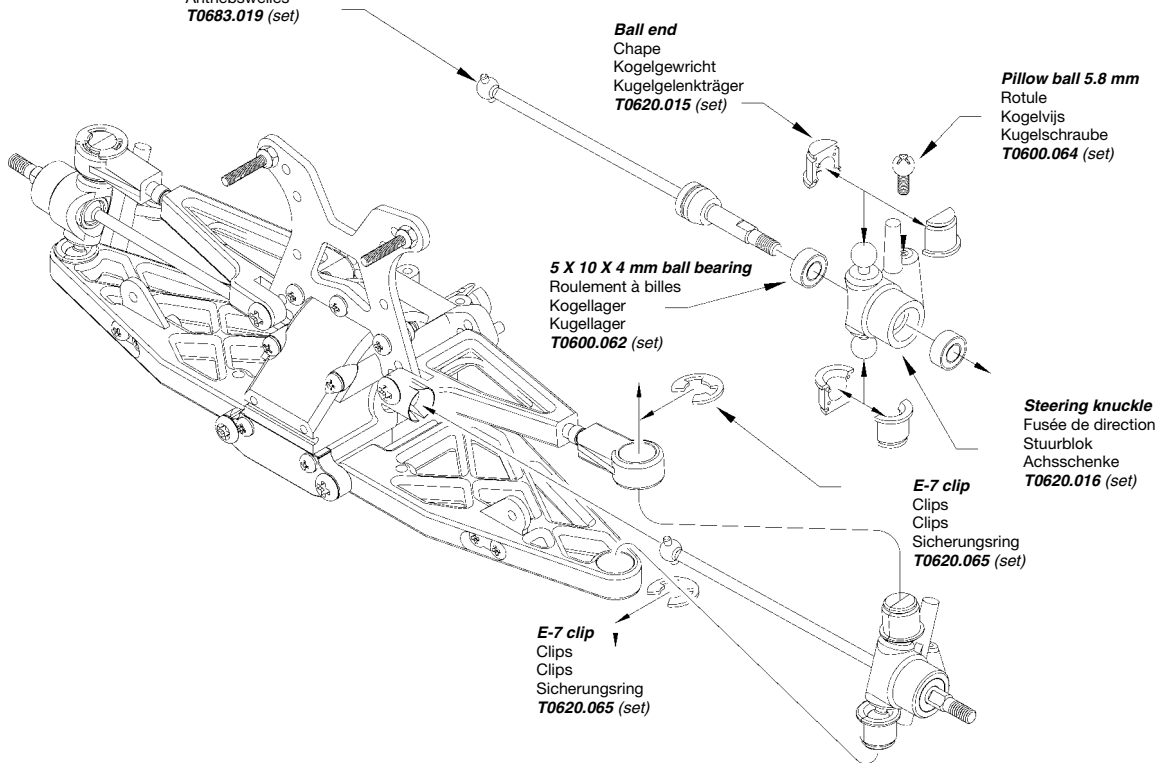

6

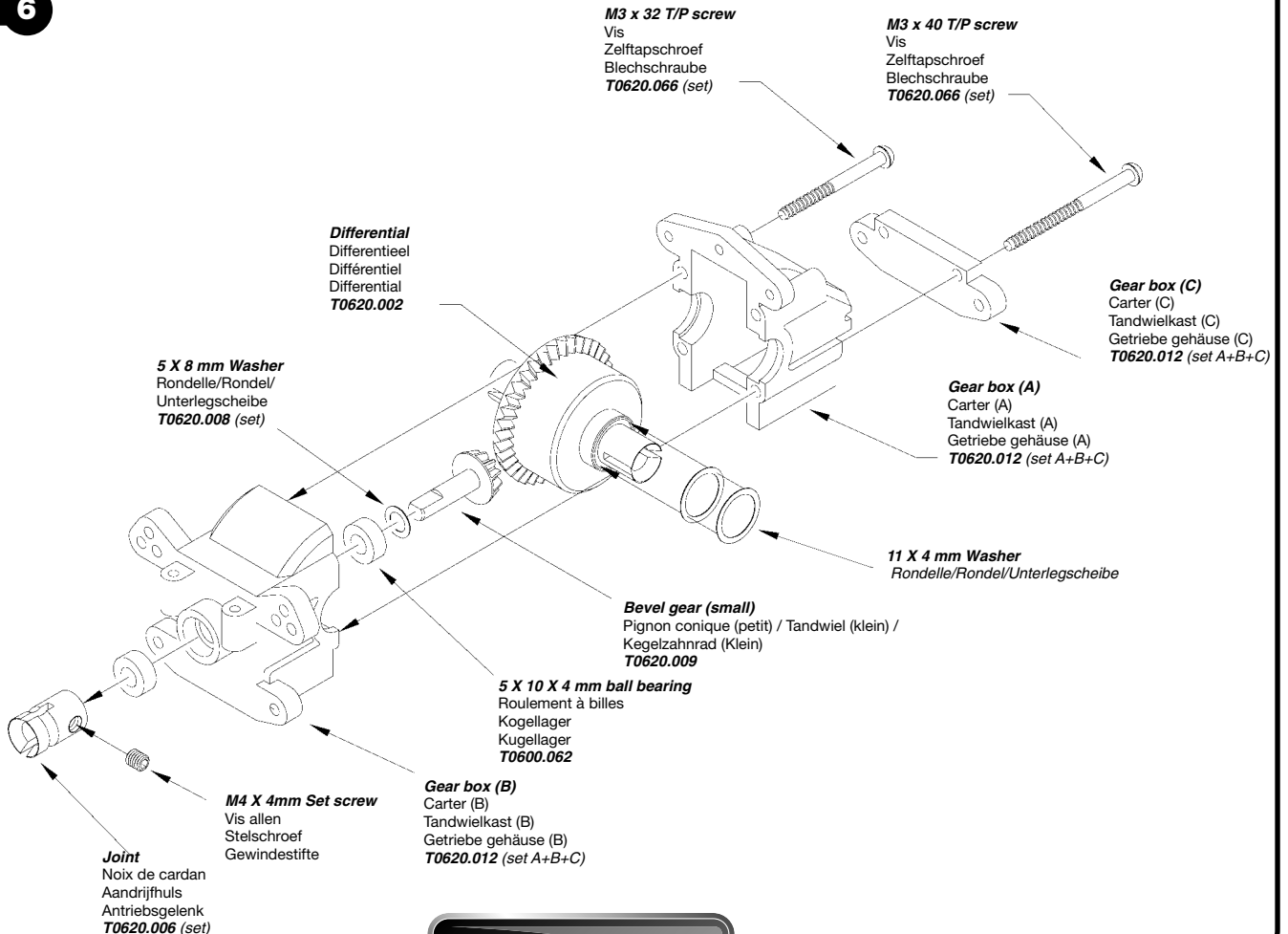

**PROTECH**

# TECHNICAL PLAN

7

**Rear lower suspension arm**  
Bras de suspension arrière inférieur  
Achterste onderste ophangingsarm  
Hinterer Querlenker unten  
T0683.003 (set)

**Rear Shock stay**  
Support d'amortisseurs AR  
Schokdämpersteun  
Stoßdämpferplatte  
T0683.005 (set)

**M3 x 10 T/P screw**  
Vis  
Zelftapschroef  
Blechschräube

**Pivot shaft**  
Axe  
As  
Welle  
T0683.004 (set)

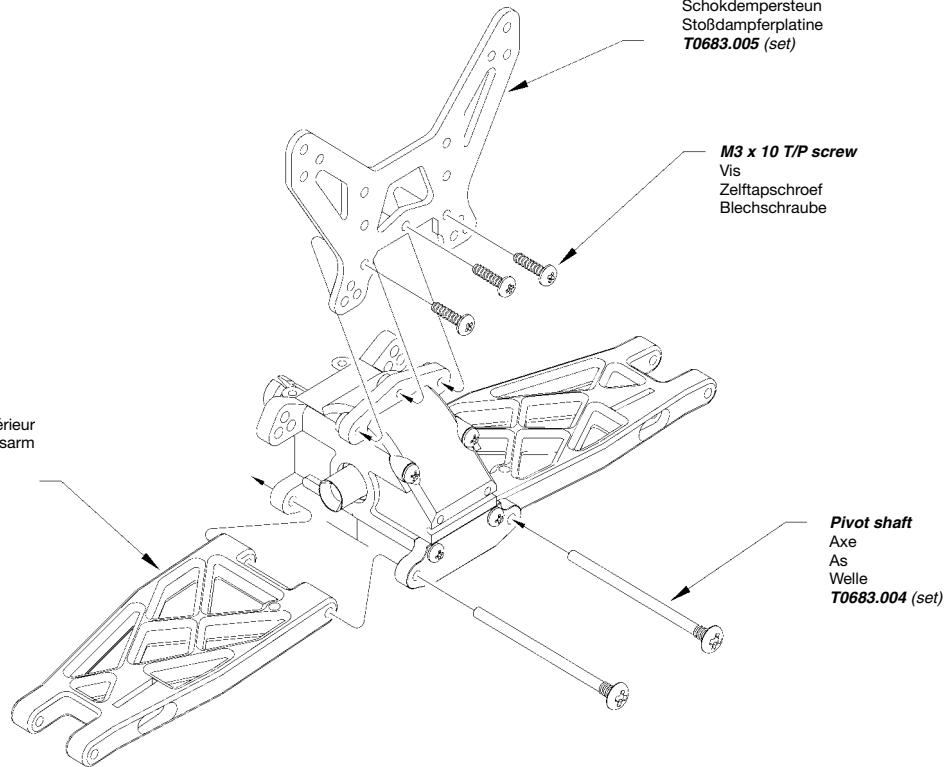

8

**M3 x 20 screw**  
Vis  
Schroef  
Schraube

**M3 Lock Nut**  
Ecrou  
Moer  
Mutter

**Shock Support**  
Support inf. d'amortisseur  
Stoßdämpferstütze  
Schokdämpersteun  
T0683.020 (set)

**M3 x 12 T/P screw**  
Vis  
Zelftapschroef  
Blechschräube

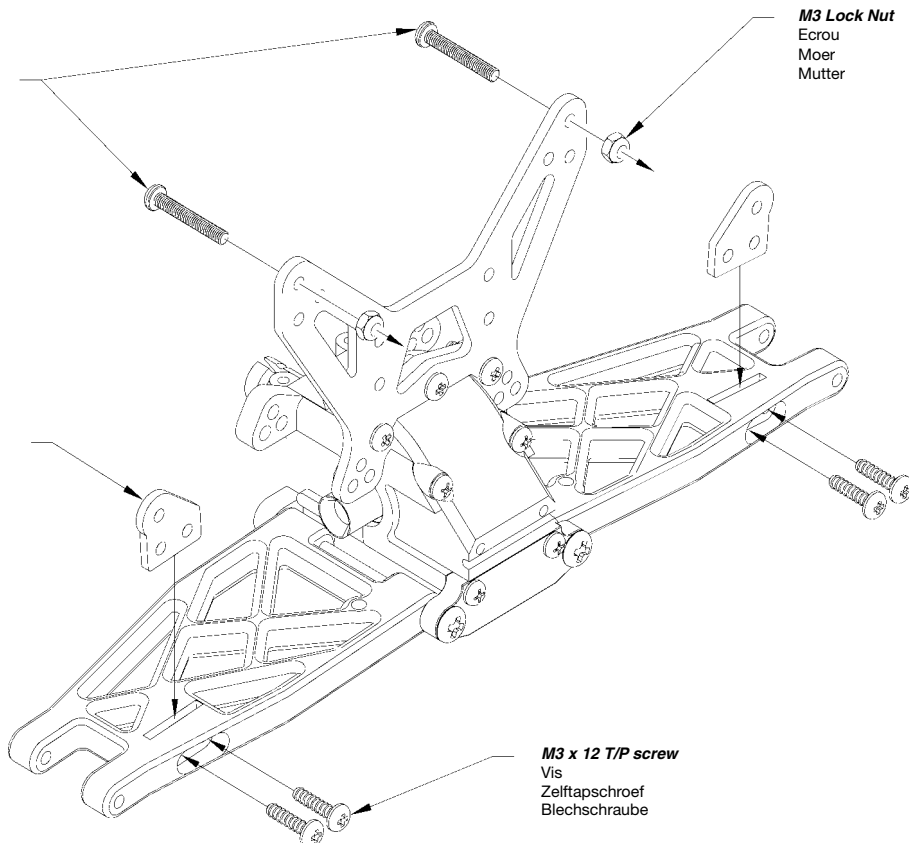

# TECHNICAL PLAN

7

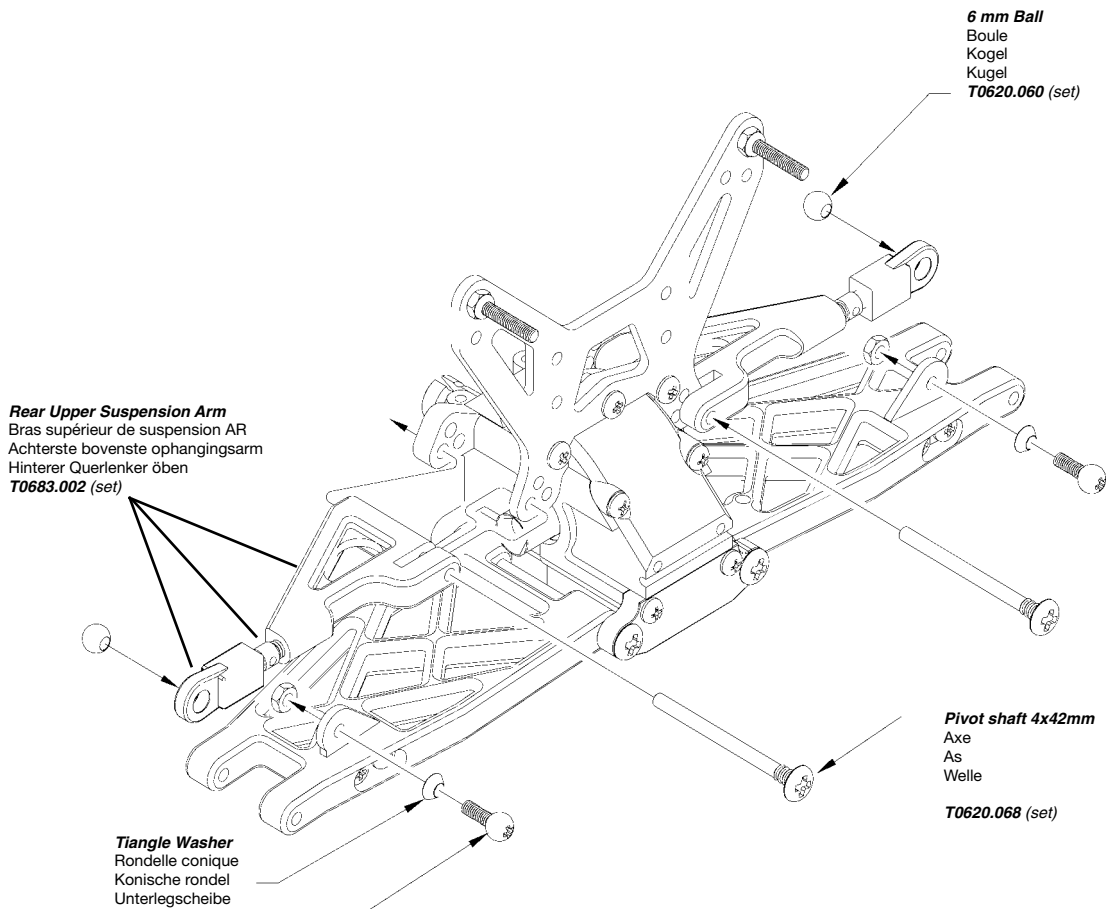

8

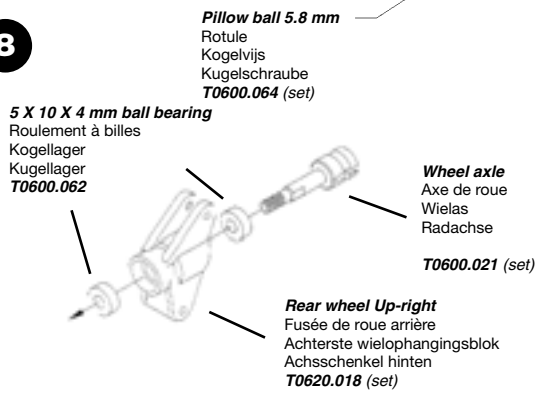

9

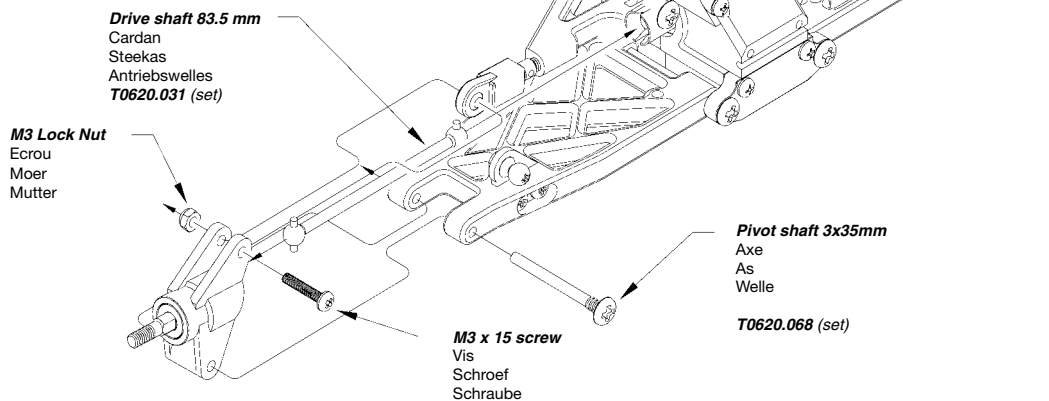

# TECHNICAL PLAN

10

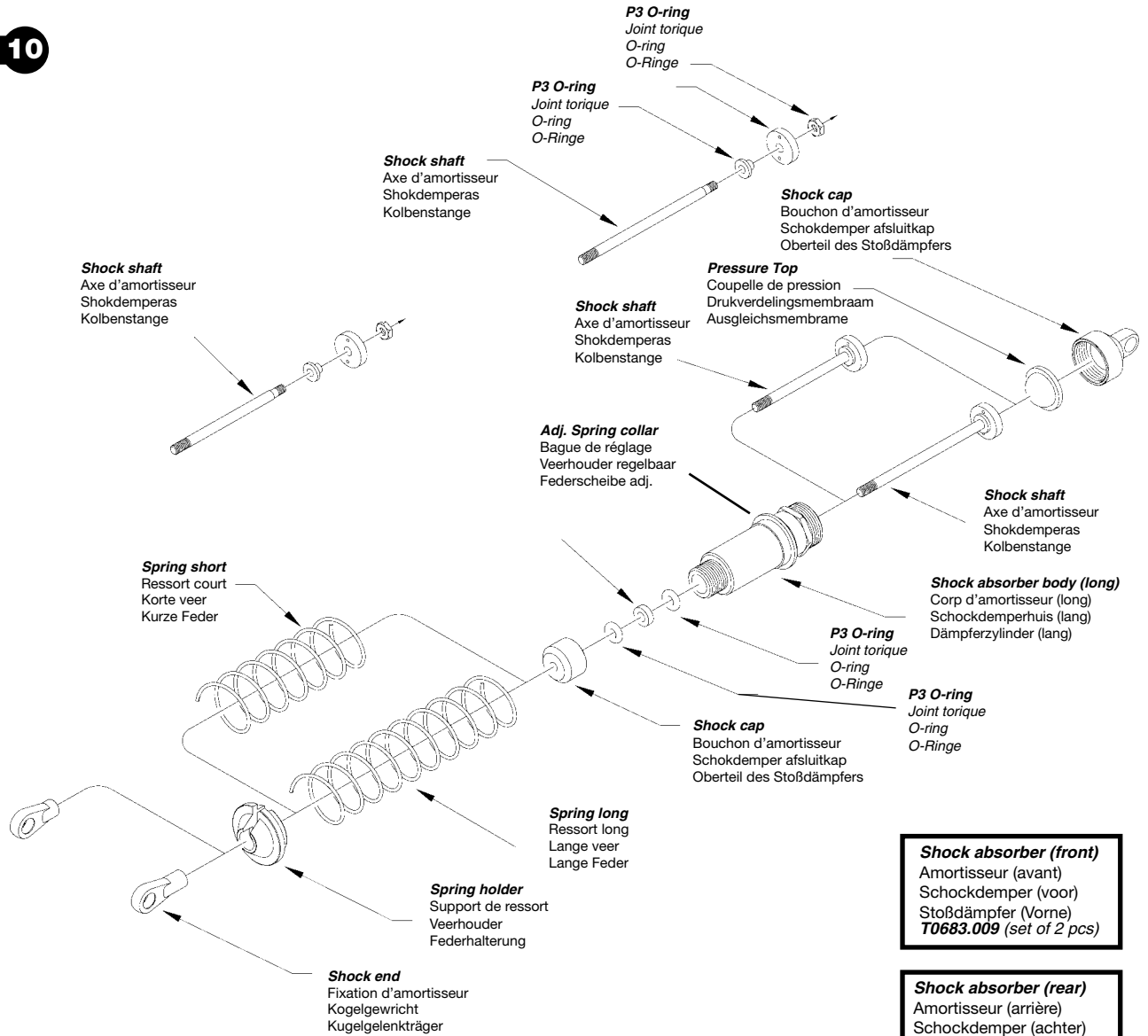

**Shock absorber (front)**  
Amortisseur (avant)  
Schokdemper (voor)  
Stoßdämpfer (Vorne)  
**T0683.009 (set of 2 pcs)**

**Shock absorber (rear)**  
Amortisseur (arrière)  
Schokdemper (achter)  
Stoßdämpfer (Hinten)  
**T0683.010 (set of 2 pcs)**

11

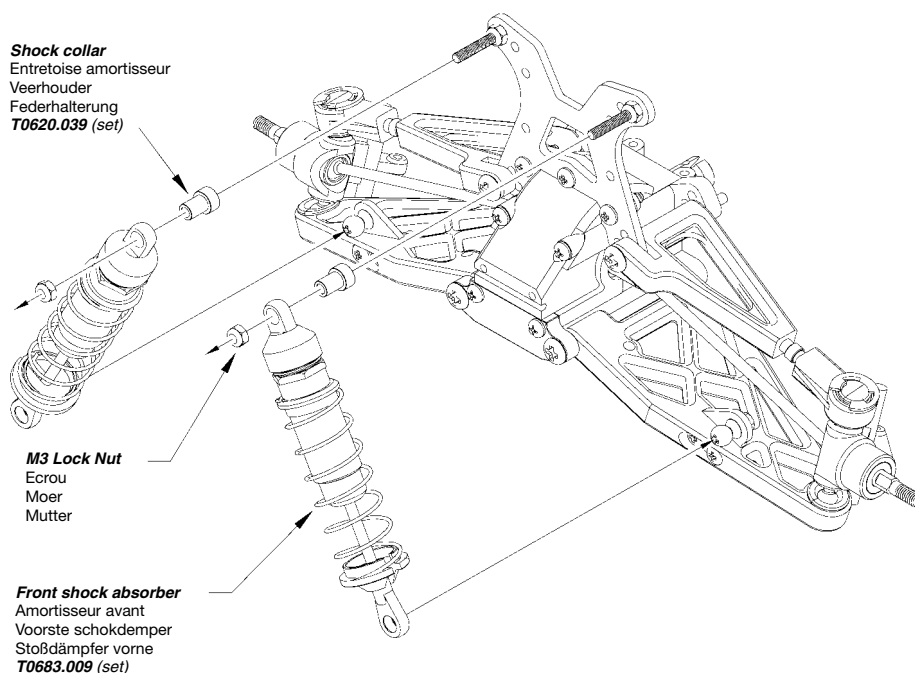

**PROTECH**

# TECHNICAL PLAN

12

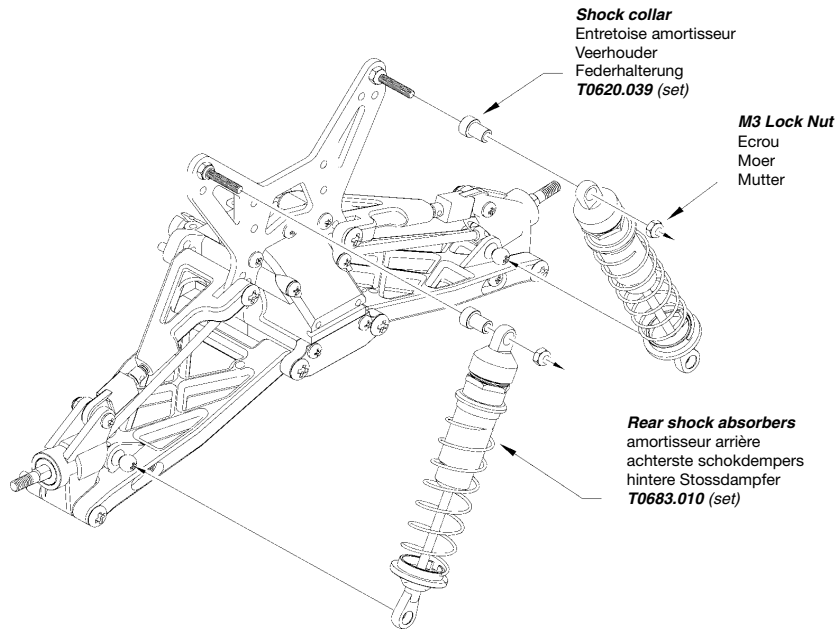

13

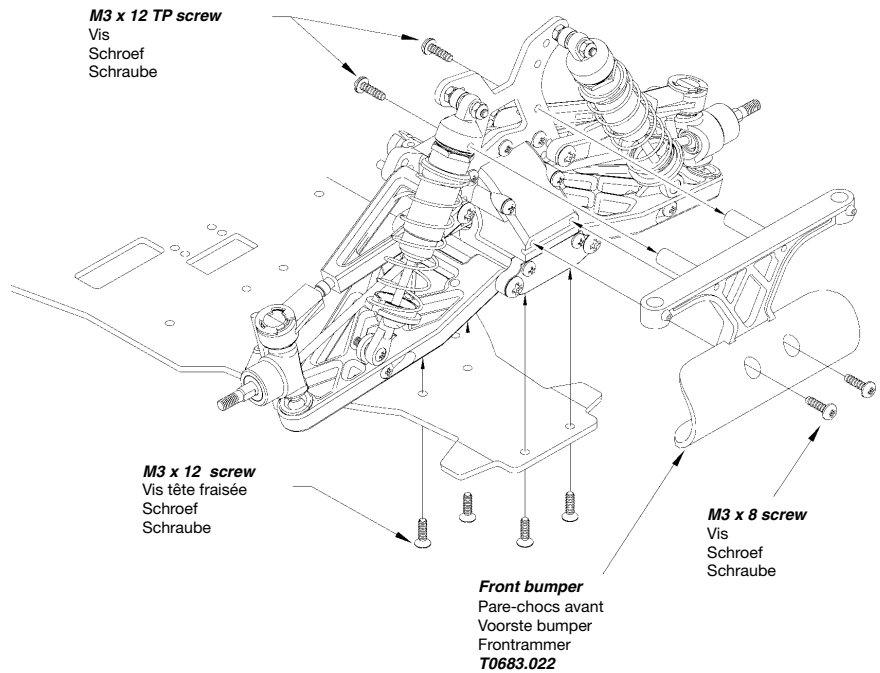

14

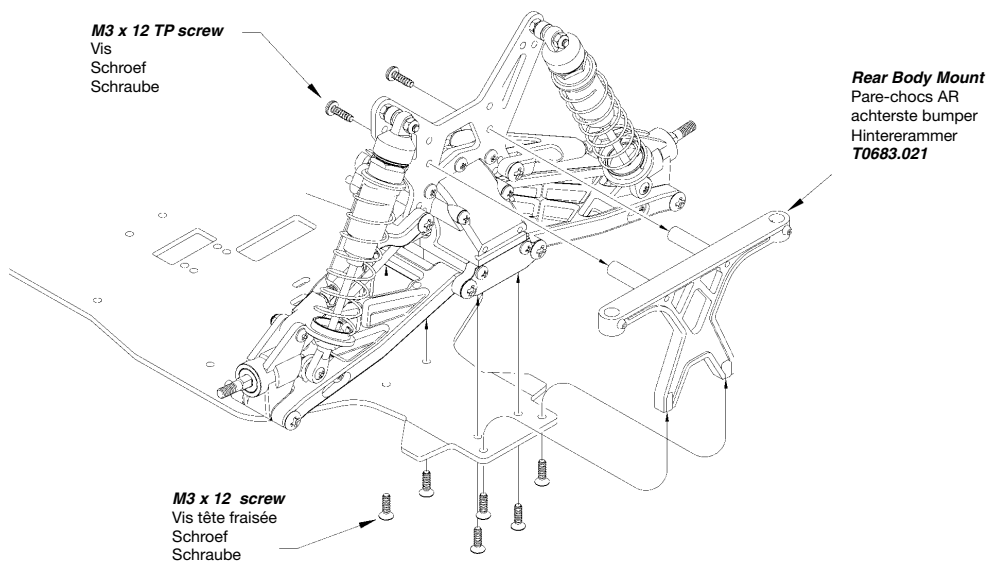

# TECHNICAL PLAN

15

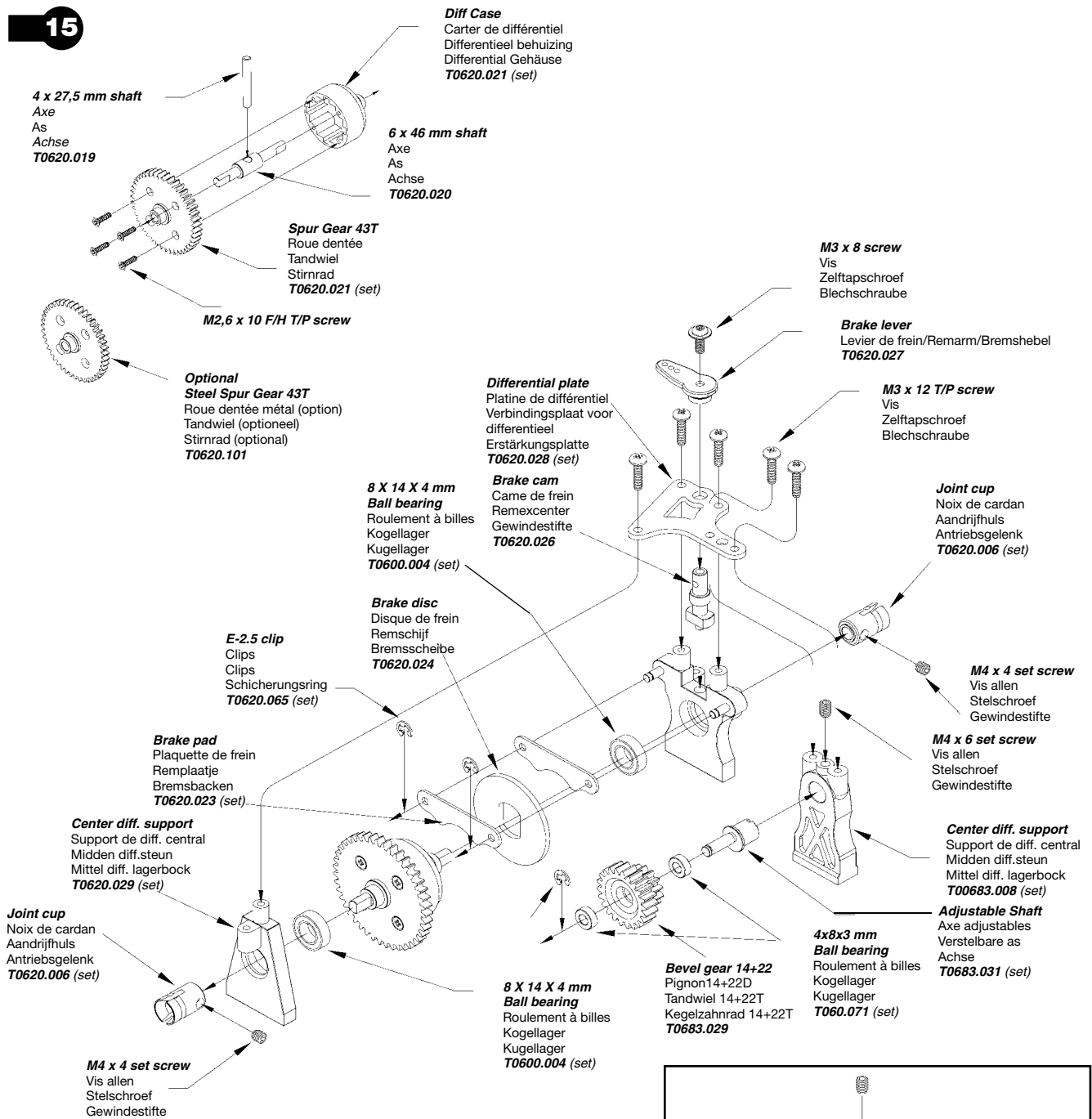

## OPTIONAL PARTS

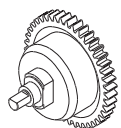

**Center Diff.**  
Différentiel Central  
Midden Differentieel  
Central Differential  
T0620.022

**5 x 18 mm shaft**  
Axe  
As  
Achse

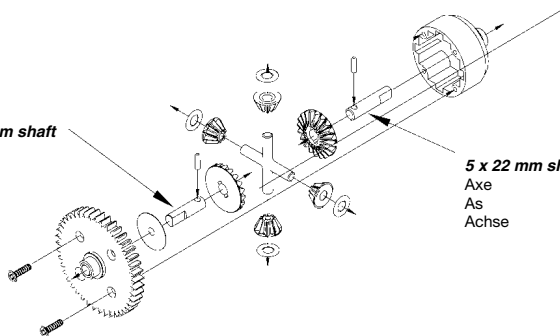

**5 x 22 mm shaft**  
Axe  
As  
Achse

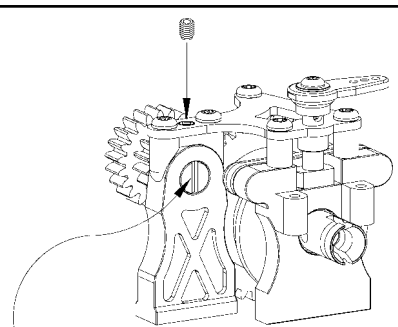

Adjust the shaft right or left and check backlash of spur gear and clutch bell. The gear must mesh without jamming then tighten the 4x6 set screw.

Regel de as naar links of rechts en controleer het spel tussen het tankwiel en de koppelingsklok. Blokkeer door de allen vijs (4x6) aan te draaien.

Ajustez l'axe vers gauche ou droite et contrôlez le jeu entre le pignon et la cloche d'embrayage. Bloquez en vissant la vis allen 4x6.

Alignieren Sie die Achse von links nach rechts und überprüfen Sie das Spiel zwischen das Zahnrad und die Kupplungsglocke. Blockieren durch andrehen von Allen Schraube 4x6.



# TECHNICAL PLAN

16

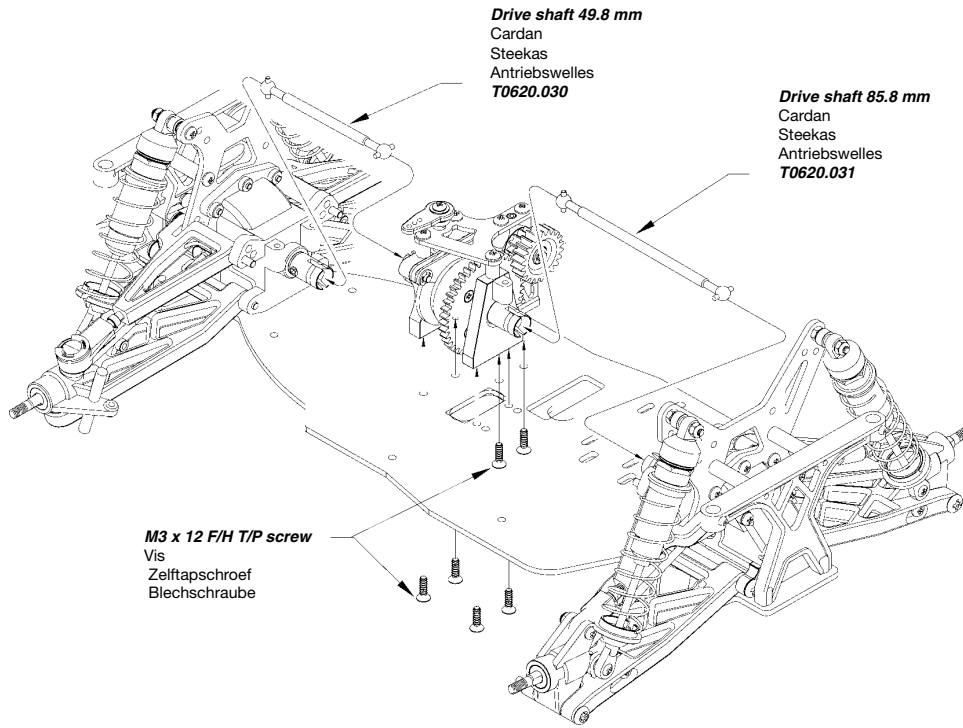

17

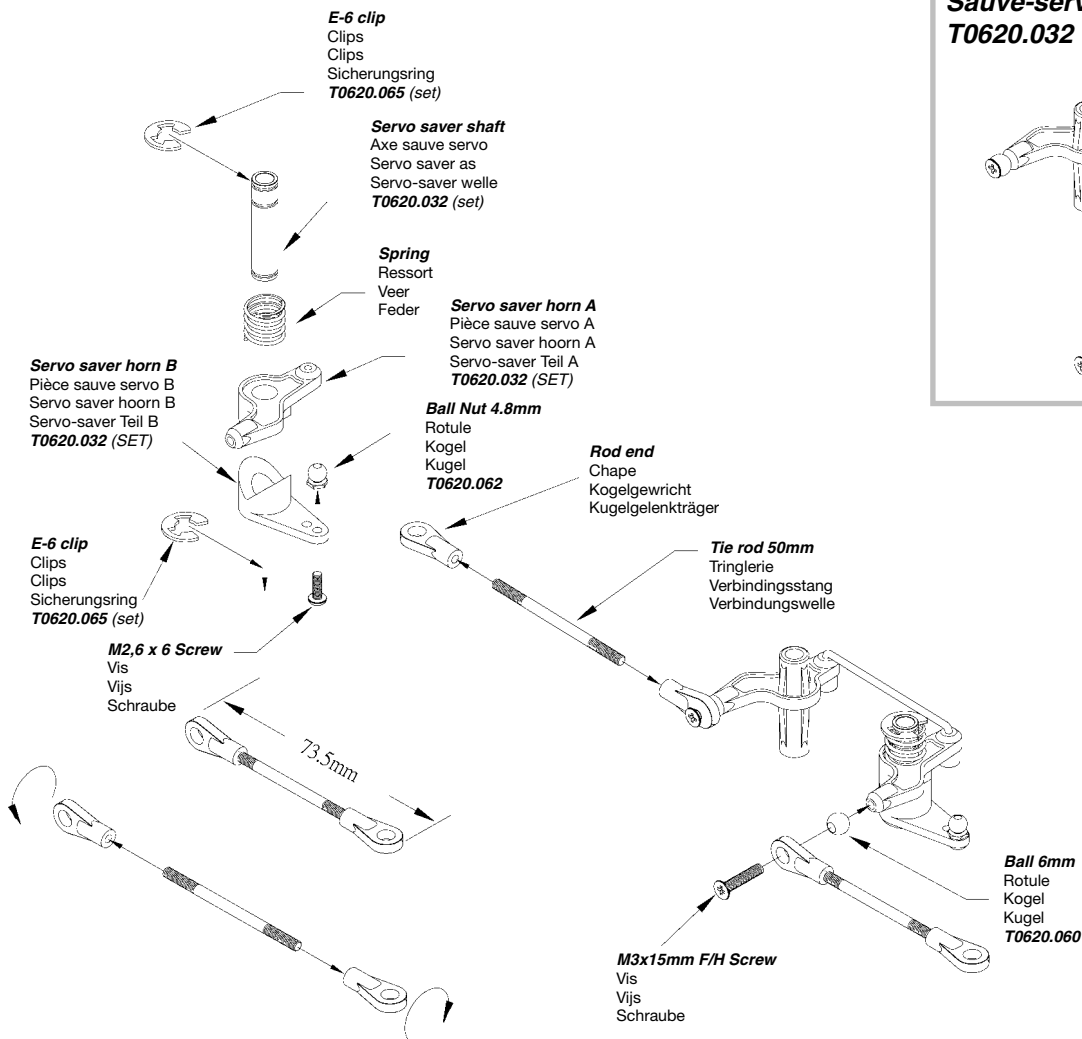

**SERVO SAVER SET**  
**Sauve-servo complet**  
T0620.032

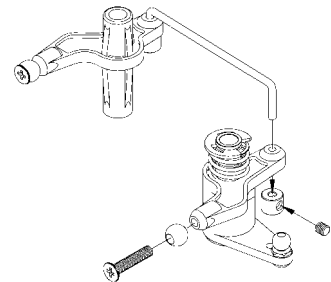

# TECHNICAL PLAN

18

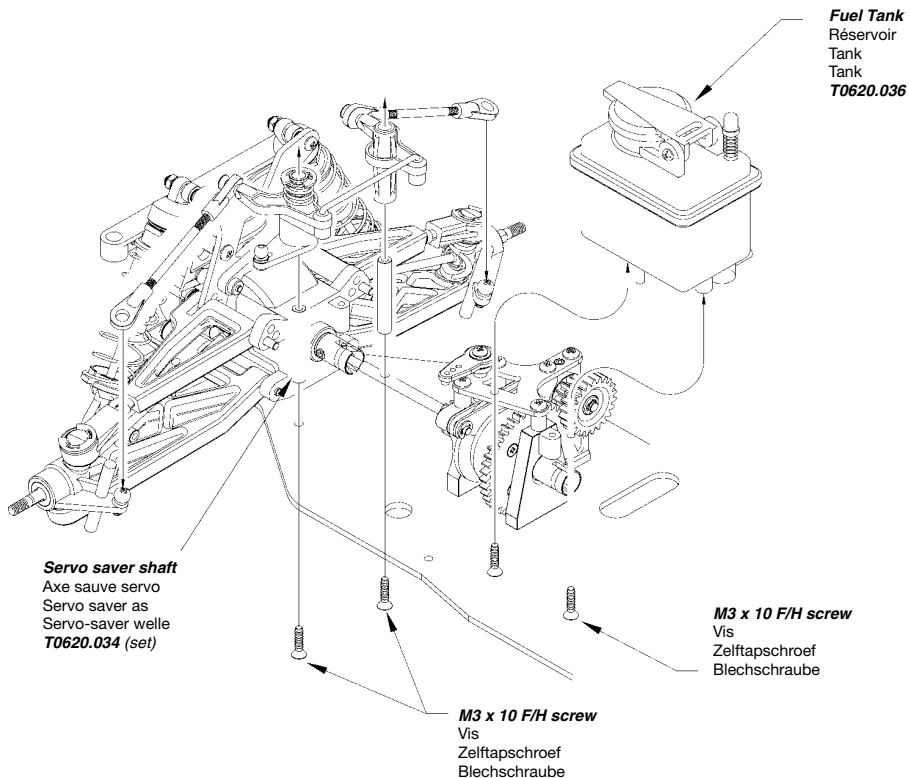

19

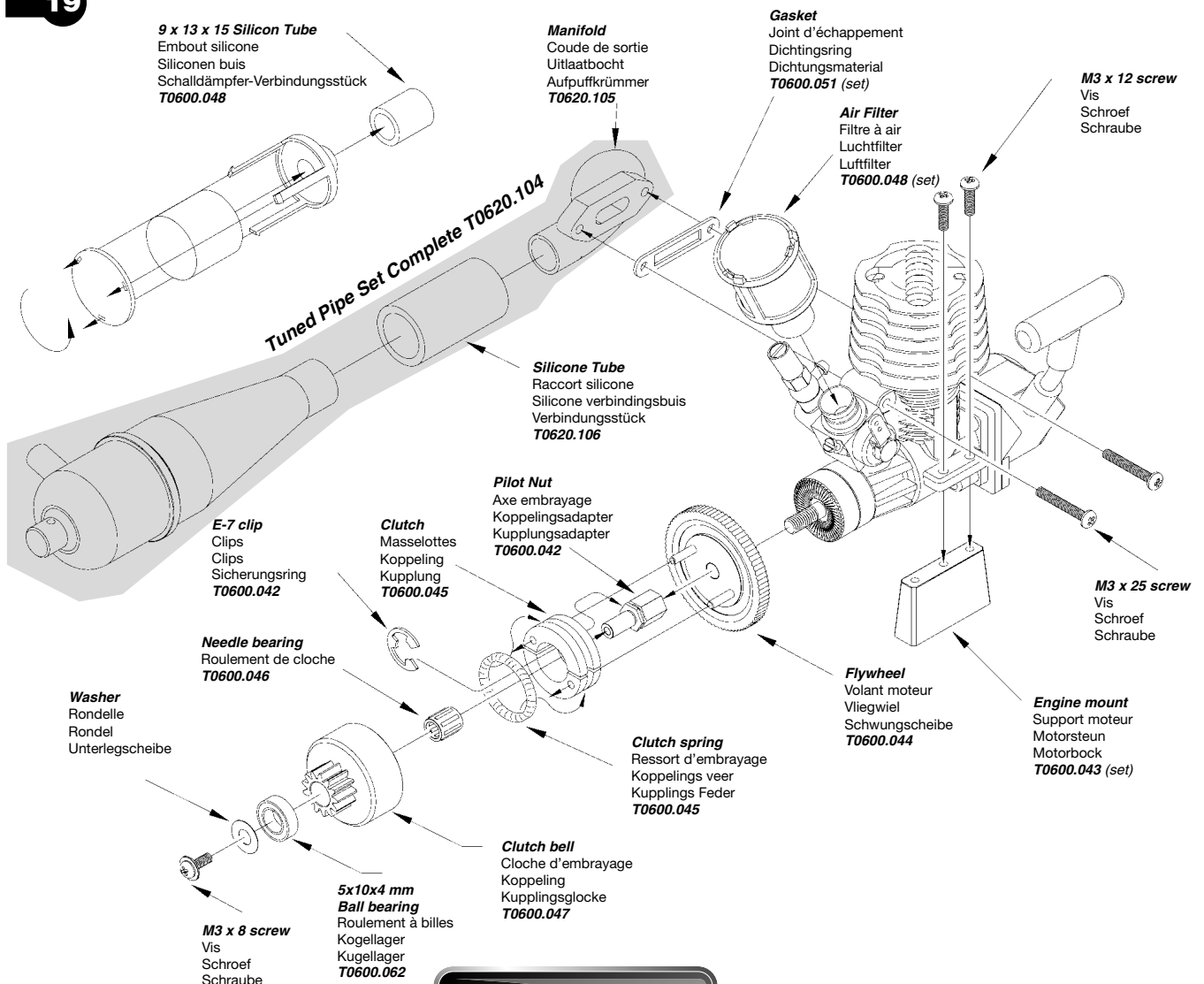

**PROTECH**

# TECHNICAL PLAN

20

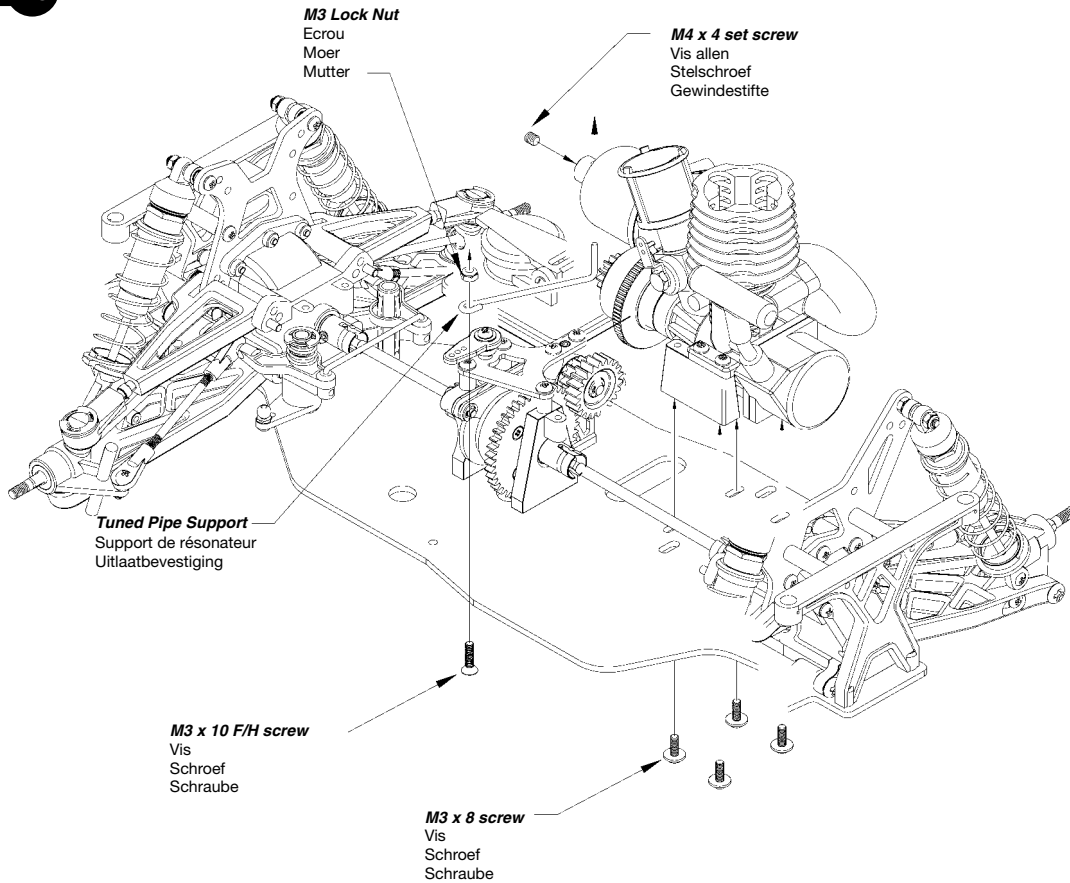

21

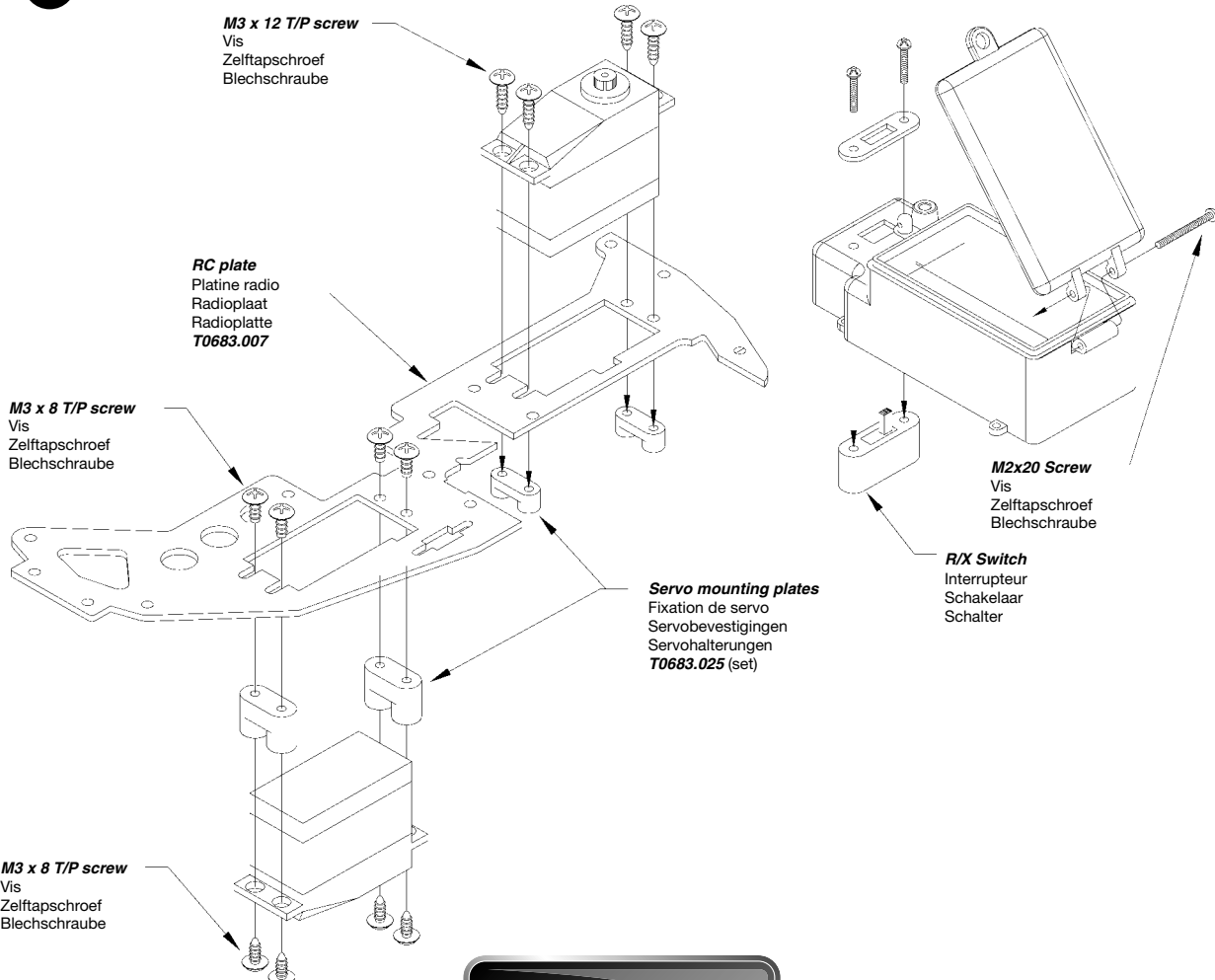

# TECHNICAL PLAN

22

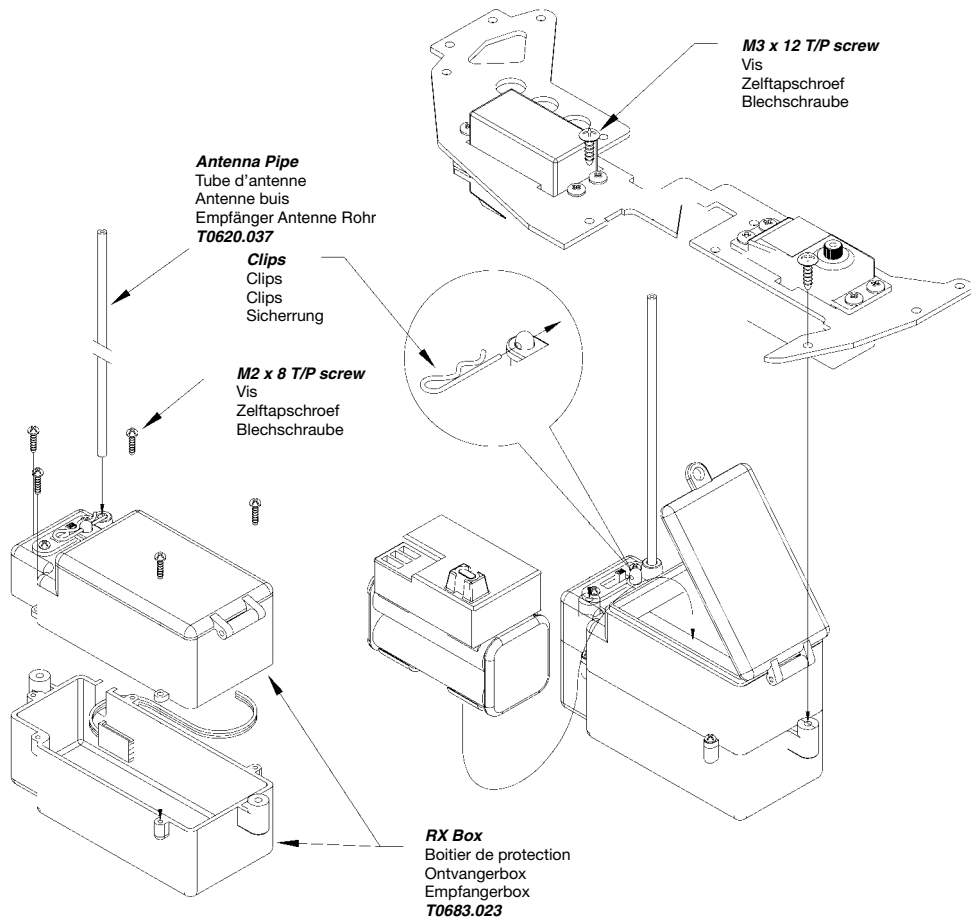

23

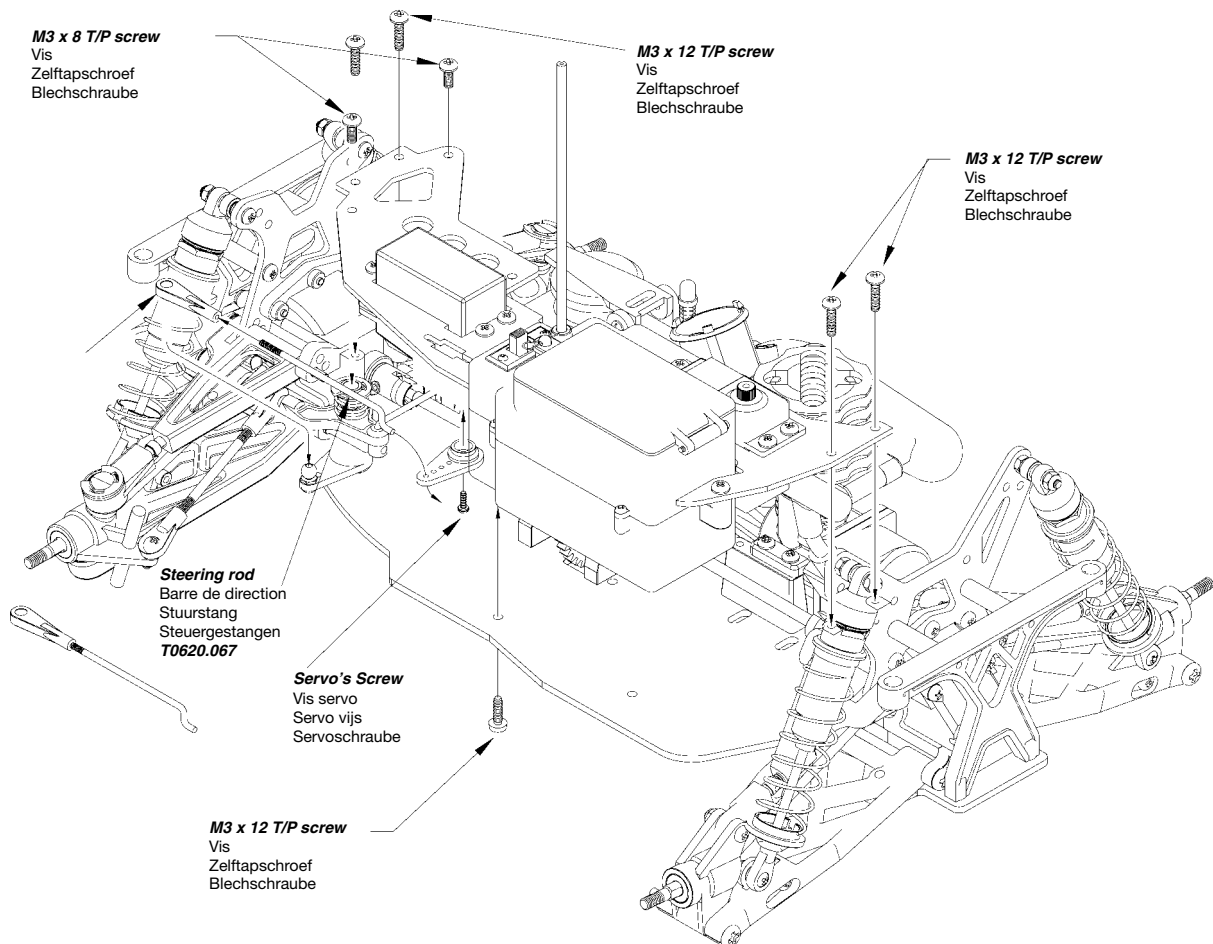

**PROTECH**

# TECHNICAL PLAN

24

**Throttle and brake linkage set**  
Tringlerie de gas et de frein

T0683.025

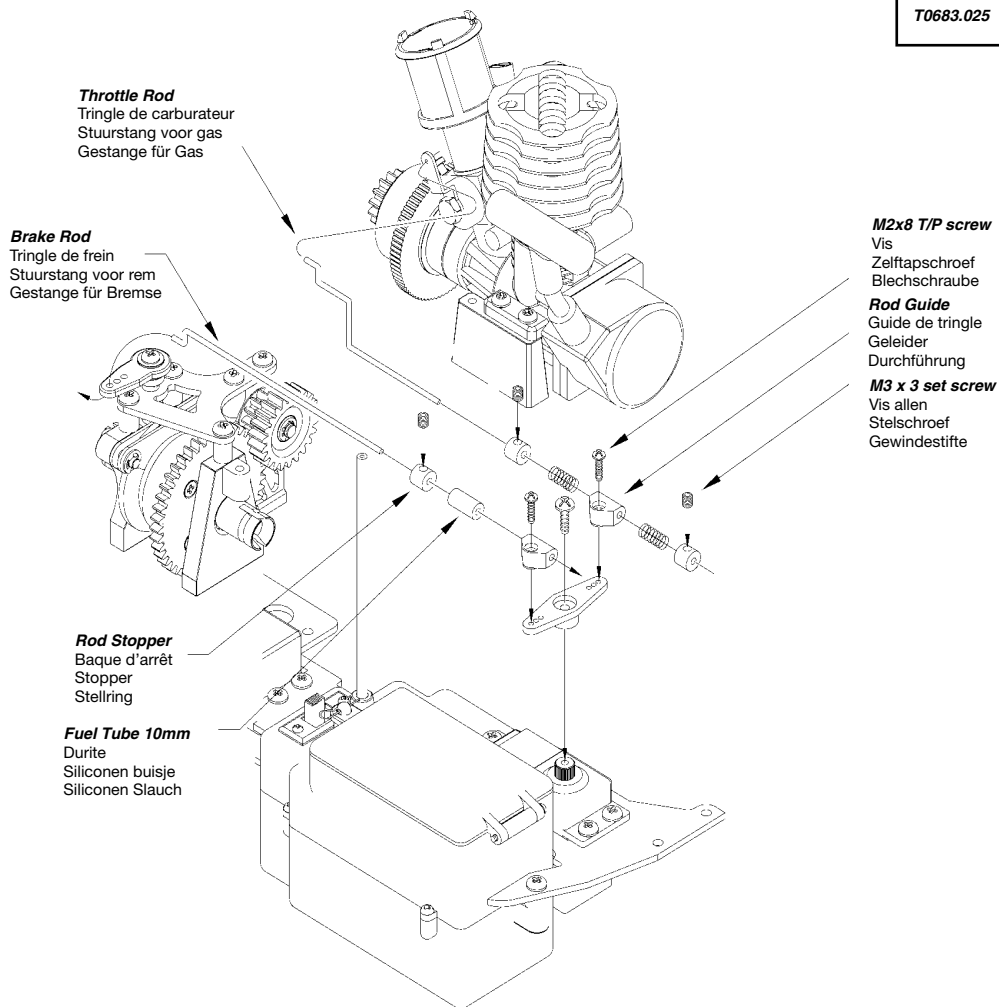

25

**NEUTRAL POSITION**  
POSITION RALENTI  
NEUTRAAL STAND  
NEUTRAL EINSTELLUNG  
1MM

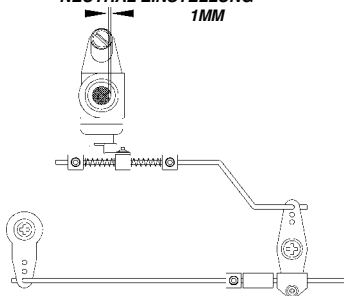

**FULL THROTTLE POSITION**  
POSITION PLEIN GAS  
VOLLEDIG GAS  
GAZ

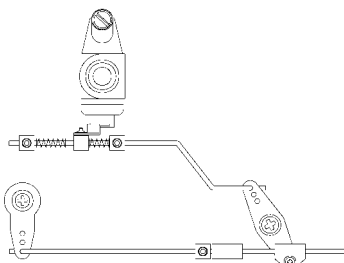

**BRAKE POSITION**  
POSITION DE FREINAGE  
REMME  
BREMSE

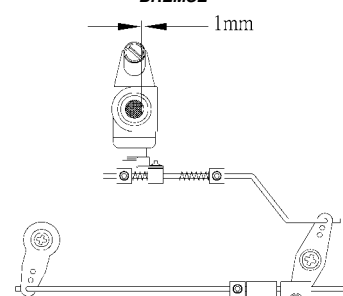

# TECHNICAL PLAN

26

**Tire**  
Pneu  
Band  
Reife  
**T0683.026 (set)**

**Rims**  
Jante  
Velg  
Felge  
**T060.050.1RE**

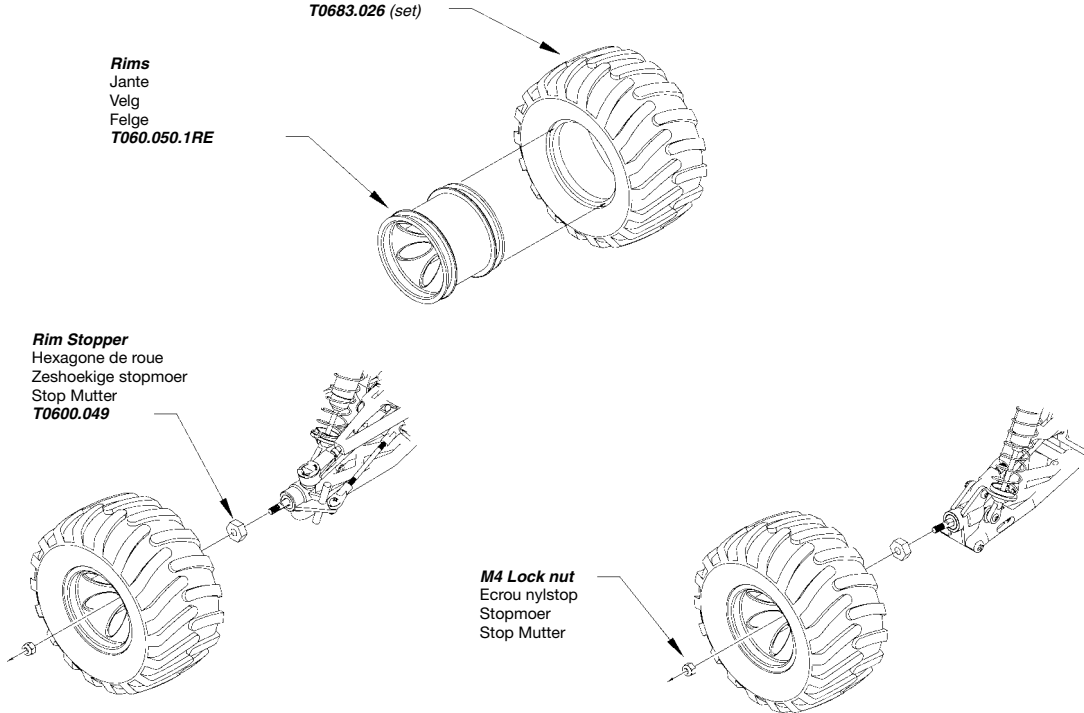

27

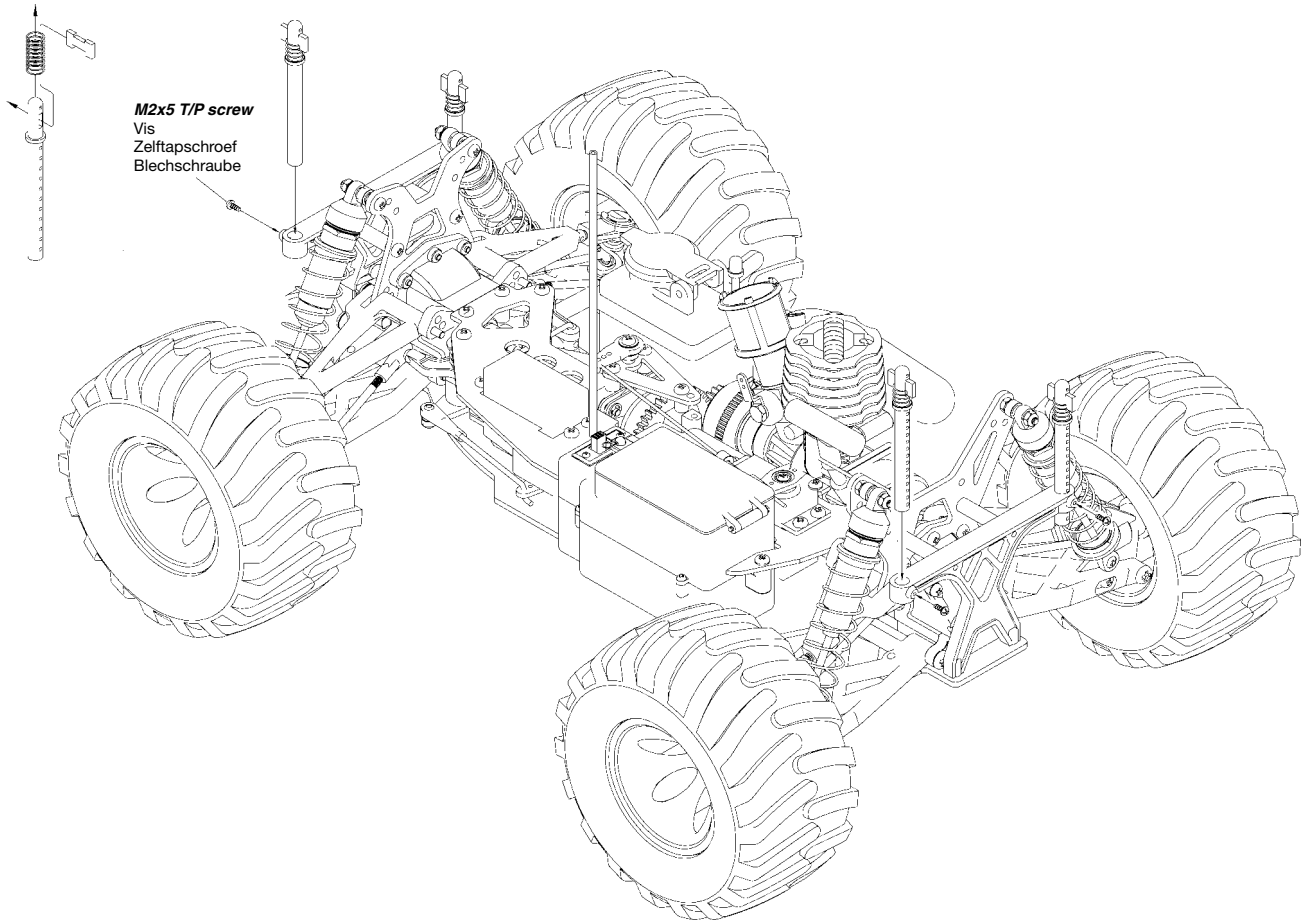

# TECHNICAL PLAN

28

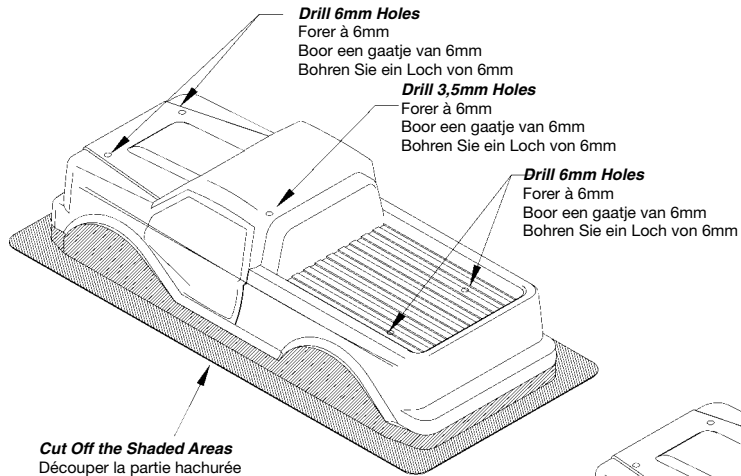



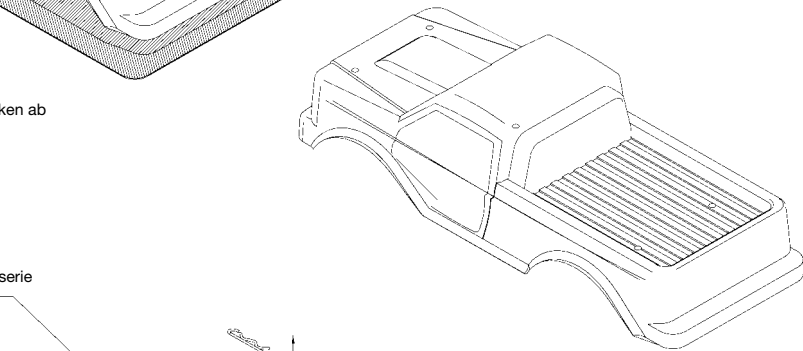



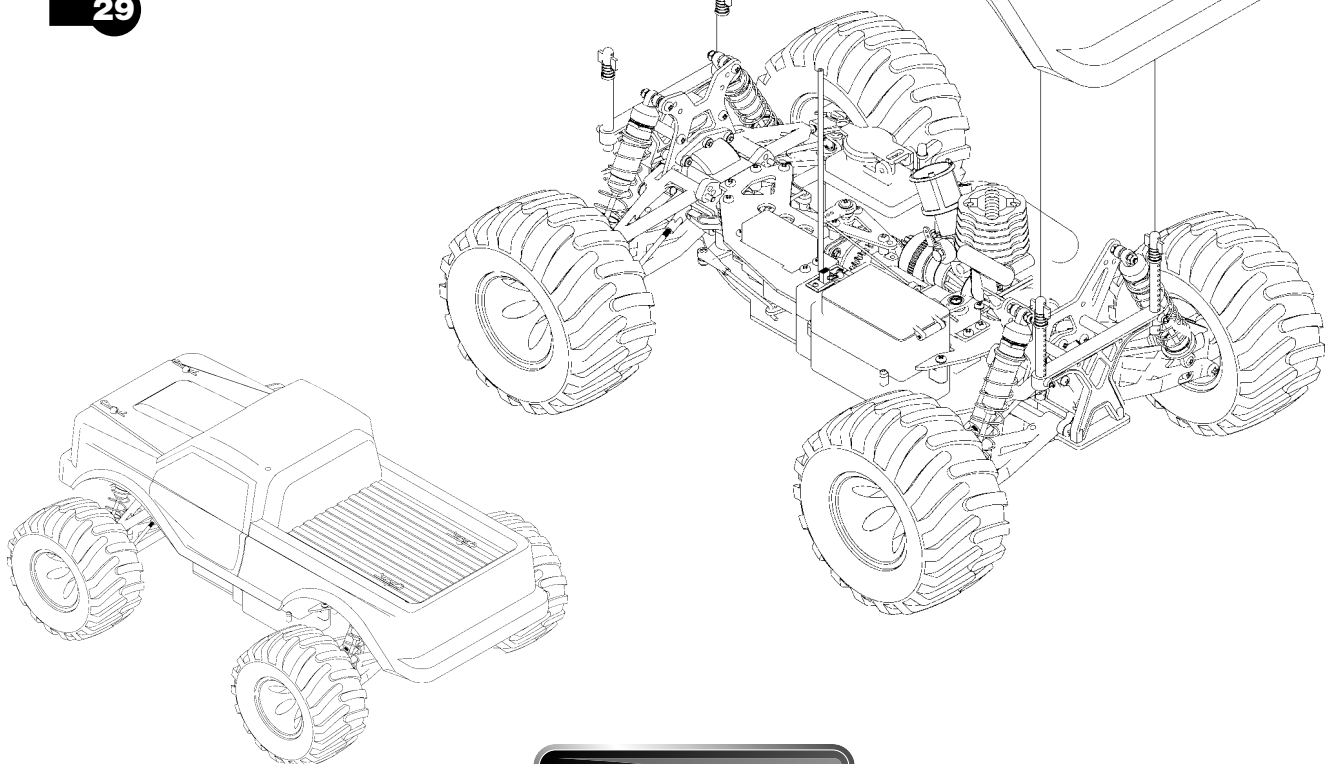



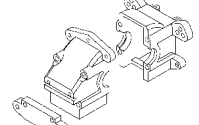
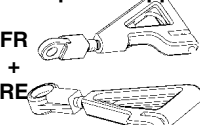
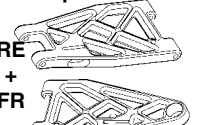
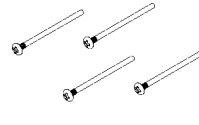
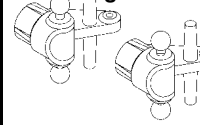

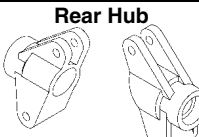

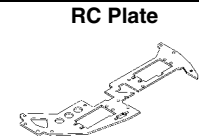
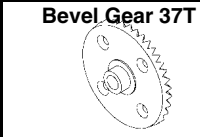

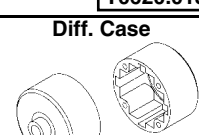
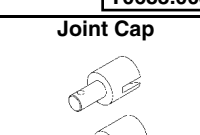
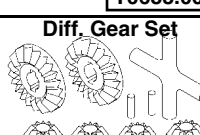
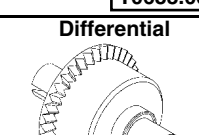
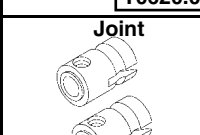
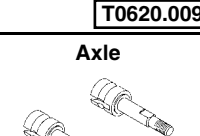

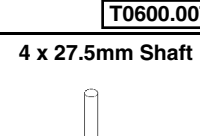
**Body Clips**  
Clips carrosserie  
Bodyclips  
Sicherung  
PA008

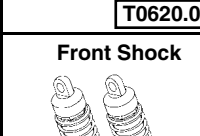
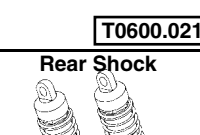

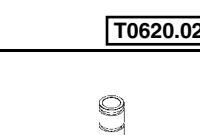
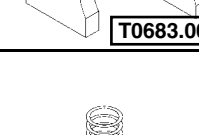
29

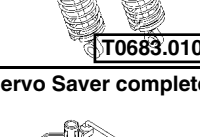
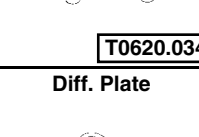

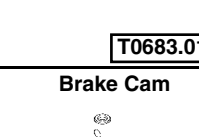
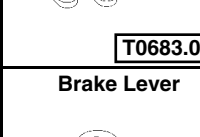
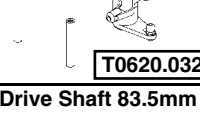
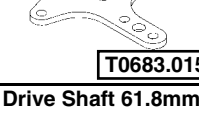
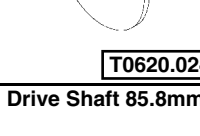
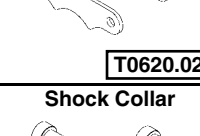
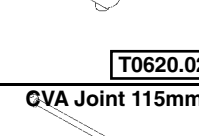
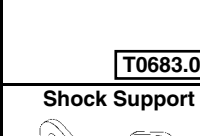
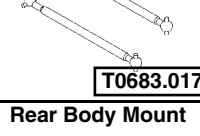
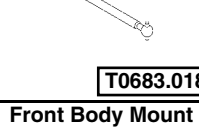
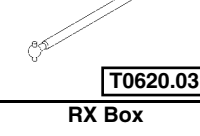
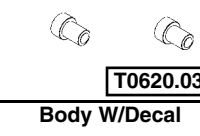
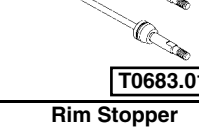
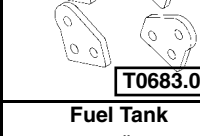
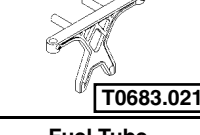

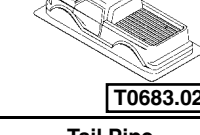
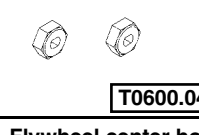
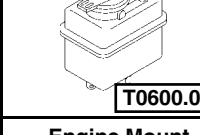
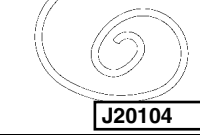
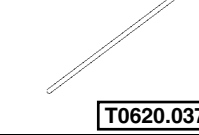
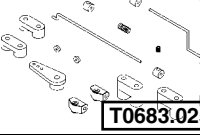
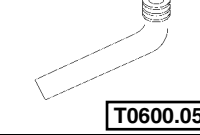
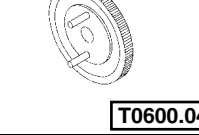
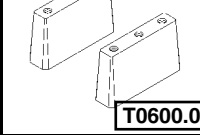





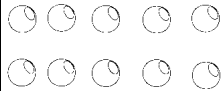

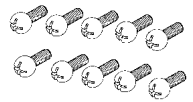







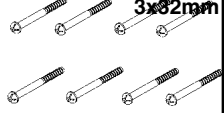

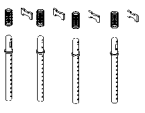
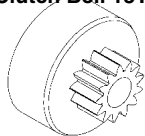

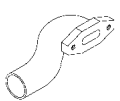



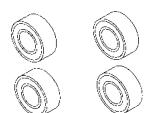
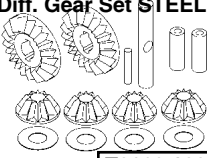

# SPARE PARTS

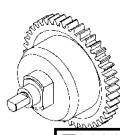
<p><b>Chassis</b></p>  <p><b>T0683.001</b></p>	<p><b>Gear Case</b></p>  <p><b>T0620.012</b></p>	<p><b>Susp. Arm Upper</b></p> <p>FR + RE</p>  <p><b>T0683.002</b></p>	<p><b>Susp. Arm Below</b></p> <p>RE + FR</p>  <p><b>T0683.003</b></p>	<p><b>Pivot Shaft 3x56mm</b></p>  <p><b>T0683.004</b></p>	<p><b>Steering Knuckle</b></p>  <p><b>T0620.016</b></p>
<p><b>Ball Holder</b></p>  <p><b>T0620.015</b></p>	<p><b>Rear Hub</b></p>  <p><b>T0620.018</b></p>	<p><b>Rear Shock Tower</b></p>  <p><b>T0683.005</b></p>	<p><b>Front Shock Tower</b></p>  <p><b>T0683.006</b></p>	<p><b>RC Plate</b></p>  <p><b>T0683.007</b></p>	<p><b>Bevel Gear 37T</b></p>  <p><b>T0620.010</b></p>
<p><b>Ring Gear 11T</b></p>  <p><b>T0620.009</b></p>	<p><b>Diff. Case</b></p>  <p><b>T0620.003</b></p>	<p><b>Joint Cap</b></p>  <p><b>T0600.007</b></p>	<p><b>Diff. Gear Set</b></p>  <p><b>T0600.005</b></p>	<p><b>Differential</b></p>  <p><b>T0620.002</b></p>	<p><b>Joint</b></p>  <p><b>T0620.006</b></p>
<p><b>Axle</b></p>  <p><b>T0600.021</b></p>	<p><b>Spur Gear 43T</b></p>  <p><b>T0620.021</b></p>	<p><b>4 x 27.5mm Shaft</b></p>  <p><b>T0620.019</b></p>	<p><b>8 x 46mm Shaft</b></p>  <p><b>T0620.020</b></p>	<p><b>Centre diff. Mounts</b></p>  <p><b>T0683.008</b></p>	<p><b>Front Shock</b></p>  <p><b>T0683.009</b></p>
<p><b>Rear Shock</b></p>  <p><b>T0683.010</b></p>	<p><b>Servo Saver Post</b></p>  <p><b>T0620.034</b></p>	<p><b>Servo Saver Horn</b></p>  <p><b>T0683.011</b></p>	 <p><b>T0683.012</b></p>	 <p><b>T0683.013</b></p>	<p><b>Steering Rod</b></p>  <p><b>T0683.014</b></p>
<p><b>Servo Saver complete</b></p>  <p><b>T0620.032</b></p>	<p><b>Diff. Plate</b></p>  <p><b>T0683.015</b></p>	<p><b>Brake Disc</b></p>  <p><b>T0620.024</b></p>	<p><b>Brake Pad</b></p>  <p><b>T0620.023</b></p>	<p><b>Brake Cam</b></p>  <p><b>T0620.026</b></p>	<p><b>Brake Lever</b></p>  <p><b>T0683.016</b></p>
<p><b>Drive Shaft 83.5mm</b></p>  <p><b>T0683.017</b></p>	<p><b>Drive Shaft 61.8mm</b></p>  <p><b>T0683.018</b></p>	<p><b>Drive Shaft 85.8mm</b></p>  <p><b>T0620.031</b></p>	<p><b>Shock Collar</b></p>  <p><b>T0620.039</b></p>	<p><b>CVA Joint 115mm</b></p>  <p><b>T0683.019</b></p>	<p><b>Shock Support</b></p>  <p><b>T0683.020</b></p>
<p><b>Rear Body Mount</b></p>  <p><b>T0683.021</b></p>	<p><b>Front Body Mount</b></p>  <p><b>T0683.022</b></p>	<p><b>RX Box</b></p>  <p><b>T0683.023</b></p>	<p><b>Body W/Decal</b></p>  <p><b>T0683.024</b></p>	<p><b>Rim Stopper</b></p>  <p><b>T0600.049</b></p>	<p><b>Fuel Tank</b></p>  <p><b>T0600.036</b></p>
<p><b>Fuel Tube</b></p>  <p><b>J20104</b></p>	<p><b>Antena Pipe</b></p>  <p><b>T0620.037</b></p>	<p><b>Linkage Set</b></p>  <p><b>T0683.025</b></p>	<p><b>Tail Pipe</b></p>  <p><b>T0600.050</b></p>	<p><b>Flywheel center hole 5mm</b></p>  <p><b>T0600.044</b></p>	<p><b>Engine Mount</b></p>  <p><b>T0600.043</b></p>
<p><b>Rim</b></p>  <p><b>T60.050.1RE</b></p>	<p><b>Tire</b></p>  <p><b>T0683.026</b></p>	<p><b>Air Cleaner</b></p>  <p><b>T0683.048</b></p>	<p><b>Needle Bearing</b></p>  <p><b>T0600.046</b></p>	<p><b>Engine Nut W/Clip</b></p>  <p><b>T0600.042</b></p>	<p><b>Shoe Clutch</b></p>  <p><b>T0600.045</b></p>

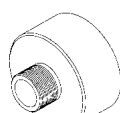

# SPARE PARTS

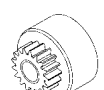
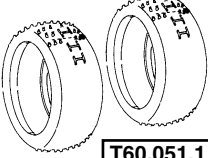
<p><b>Clutch Spring</b></p>  <p><b>T60.034</b></p>	<p><b>6mm Ball</b></p>  <p><b>T0620.060</b></p>	<p><b>Body Clip</b></p>  <p><b>PA008</b></p>	<p><b>Pillow Ball 6mm</b></p>  <p><b>T0600.064</b></p>	<p><b>Ball Nut 4.8mm</b></p>  <p><b>T0620.062</b></p>	<p><b>Ball Bearing 5x10x4</b></p>  <p><b>T0600.062</b></p>	
<p><b>5x10x4 Ball Bearing</b></p>  <p><b>T0600.006</b></p>	<p><b>Ball End</b></p>  <p><b>T0620.064</b></p>	<p><b>Clip Set</b></p>  <p><b>T0683.028</b></p>	<p><b>Washer 11x14mm</b></p>  <p><b>T0620.011</b></p>	<p><b>5x8mm Washer</b></p>  <p><b>T0620.008</b></p>	<p><b>TP Screw 3x40mm 3x32mm</b></p>  <p><b>T0620.066</b></p>	
<p><b>Pivot 3x42mm 3x35mm</b></p>  <p><b>T0620.068</b></p>	<p><b>P3-P4 O-Ring</b></p>  <p><b>T0620.014</b></p>	<p><b>Body Post</b></p>  <p><b>T0620.055</b></p>	<p><b>Clutch Bell 13T</b></p>  <p><b>T0620.016</b></p>	<p><b>Silicone Tube</b></p>  <p><b>T0620.106</b></p>	<p><b>Manifold</b></p>  <p><b>T0620.105</b></p>	
<p><b>Tuned Pipe Set</b></p>  <p><b>T0620.104</b></p>	<p><b>Slow Up Gear</b></p>  <p><b>T0683.029</b></p>	<p><b>Gear Mount</b></p>  <p><b>T0683.030</b></p>	<p><b>Adjustable Shaft</b></p>  <p><b>T0683.031</b></p>	<p><b>4x6 Set Screw</b></p>  <p><b>T0683.032</b></p>	<p><b>Ball Bearing 4x8x3</b></p>  <p><b>T060.071</b></p>	
<p><b>5x10x4mm Ball Bearing</b></p>  <p><b>T0600.062</b></p>						
<p><b>OPTIONAL PARTS</b></p>	<p><b>Diff. Gear Set STEEL</b></p>  <p><b>T0683.100</b></p>	<p><b>Flywheel for SG</b></p>  <p><b>T0620.033</b></p>	<p><b>Engine Nut for SG Shaft</b></p>  <p><b>T0620.034</b></p>	<p><b>Center Diff.</b></p>  <p><b>T0620.022</b></p>	<p><b>5x8x3mm Ball Bearing</b></p>  <p><b>T0660.200</b></p>	
	<p><b>Split Clutch Bell</b></p>  <p><b>T0683.101</b></p>	<p><b>Clutch Gear 16T</b></p>  <p><b>T0683.102</b></p>	<p><b>Clutch Gear 17T</b></p>  <p><b>T0683.103</b></p>	<p><b>Clutch Gear 18T</b></p>  <p><b>T0683.104</b></p>	<p><b>Clutch Gear 19T</b></p>  <p><b>T0683.105</b></p>	<p><b>Clutch Bell 17T</b></p>  <p><b>T0683.106</b></p>
	<p><b>Tire</b></p>  <p><b>T60.051.1</b></p>					

# VX 18 ENGINE SPARE PARTS WITH STANDART CARBURATOR

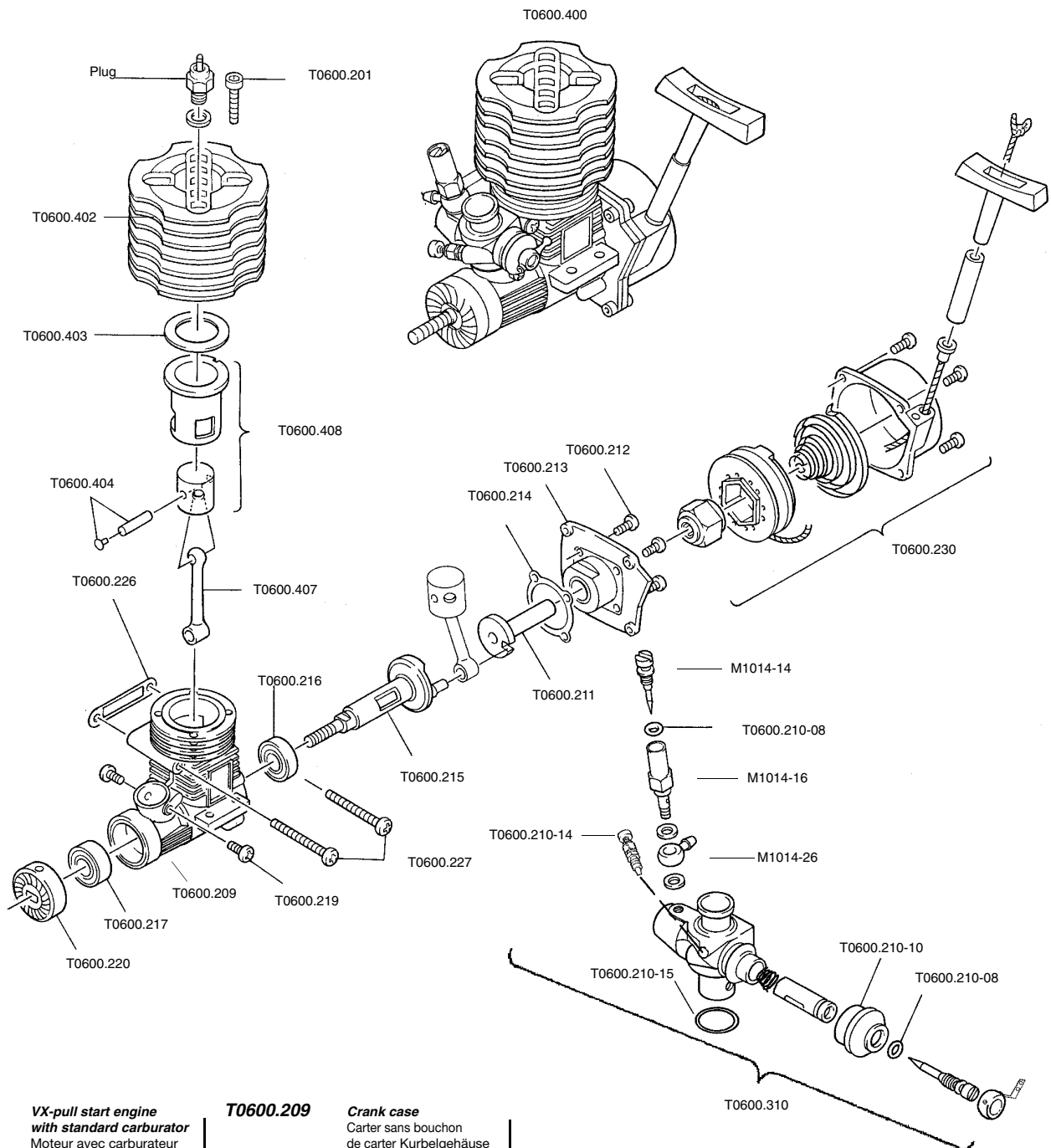

- T0600.400** *VX-pull start engine with standard carburator*  
Moteur avec carburateur standard et lanceur  
Motor met standard carburator en trekstarter  
Motor mit Standard carburator und Seilzugstarter
- T0600.201** *Cylinderhead screw*  
Vis pour culasse  
Schraube für Zylinderkopf  
Vijs voor cilinderkop
- T0600.402** *Cylinderhead*  
Culasse  
Zylinderkopf  
Cilinderkop
- T0600.403** *Cylinderhead gasket*  
Joint de culasse  
Dichtung  
Dichtingsring
- T0600.404** *Piston pin*  
Axe de piston  
Kolbenbolzen  
Zuigerpen
- T0600.407** *Conrod*  
Bielle  
Pleuel  
Drijfstang
- T0600.408** *Piston & cylinder set*  
Chemise et piston  
Zylinder und Kolben  
Cilinder en

- T0600.209** *Crank case*  
Carter sans bouchon de carter  
Kurbelgehäuse ohne Deckel  
Motorbehuizing
- T0600.210-8** *Carburator needle o-ring set*  
O-ring set  
O-ring satz  
O-ring set
- T0600.210-10** *Dust rubber protection*  
Soufflet de carburateur  
Vergaser Gumimanchet  
Carburatorbalg
- T0600.210-14** *Idling adj. screw set*  
Vis de butée  
Drösselschraube  
Leegloopregelvijs
- T0600.210-15** *O-ring outer carburator*  
O-ring  
O-ring  
O-ring
- T0600.211** *One way start shaft*  
Axe de lanceur  
Seilzugstarterachse  
Trekstarteras
- T0600.212** *Rear cover screw*  
Vis de bouchon de carter  
Schrauben für Kurbelgehäuse  
Vijzen voor deksel

- T0600.213** *Rear cover*  
Bouchon de carter  
Deckel für Kurbelgehäuse  
Deksel
- T0600.214** *Rear cover gasket*  
Joint de carter  
Dichtung  
Dichting
- T0600.215** *Crank shaft*  
Vilbrequin  
Kurbelwelle  
Krukas
- T0600.216** *Rear ball bearing*  
Roulement à billes arrière  
Hinteres Kugellager  
Kogellager achteraan
- T0600.217** *Front ball bearing*  
Roulement à billes avant  
Vorderes Kugellager  
Kogellager vooraan
- T0600.219** *Carburator screw*  
Vis de carburateur  
Vergaser-Schraube  
Carburator vijs
- T0600.220** *Drive washer*  
Plateau  
Mitnehmerscheibe  
Meenemer

- T0600.226** *Muffler gasket*  
Joint d'échappement  
Auspuffdichtung  
Uitlaatpakking
- T0600.227** *Muffler screw*  
Vis d'échappement  
Schalldämpferschraube  
Uitlaatvijzen
- T0600.230** *Recoil assembly*  
Lanceur complet  
Seilzugstarter  
Trekstarter
- T0600.310** *Carburator*  
Carburateur  
Vergaser  
Carburator
- M1014-14** *Main needle*  
Pointeau  
Düselnadel  
Naald
- M1014-16** *Main needle support*  
Support de pointeau  
Düselnadel Stutze  
Naald steun
- M1014-26** *Fuel supply nipple*  
Prise de carburant  
Kraftstoffnippel  
Brandstofftoevoernippel

**PROTECH**

• Attention: an engine set "lean" gives a better performance but results in higher temperatures, less lubrication and it generates a premature wear of the parts or it could block the engine (overheating the engine). A "rich" setting gives a little bit less performance but it improves the cooling, lubrication and therefore a longer life of the engine.

• Let op: een motor die "arm" afgesteld is geeft een betere prestatie maar dit resulteert ook in hogere temperaturen, een lagere viscositeit en kan een sneller verslijt van de onderdelen tot gevolg hebben of de motor blokkeren (oververhitting van de motor). Een "rijke" instelling geeft iets mindere prestaties maar bevordert de koeling, viscositeit en daarom een langer leven van de motor.

**RICH = RIJK** (meer brandstof) - **LEAN = ARM** (minder brandstof)

• Achtung: "Magere" Gemischeinstellung führt zu eine bessere Leistung jedoch führt es zu erhöhter Motortemperatur, weniger Schmierung und es erzeugt eine vorzeitige Abnutzung der Teile oder es könnte den Motor blockieren (überhitzung des Motors). Eine "Fette" Gemischeinstellung führt zu etwas weniger Leistung aber zu mehr Kühlung und Schmierung, somit zu eine höhere Lebensdauer.

**RICH = FETT** (mehr Kraftstoff) - **LEAN = MAGERE** (weniger Kraftstoff)

• Attention: un moteur réglé "pauvre" aura de meilleures performances mais provoque une hausse de température, diminue la lubrification et engendre une usure prématurée des pièces ou peut provoquer un blocage du moteur (surchauffe du moteur) si le mélange est trop pauvre. Un réglage un peu plus "riche" diminue légèrement les performances mais améliore le refroidissement, la lubrification et augmente la longévité du moteur. **RICH = RICHE** (plus de carburant) - **LEAN = PAUVRE** (moins de carburant)

**FACTORY SETTINGS**

- High speed needle factory setting: 4 turns
- Low speed needle factory setting: 1 1/2 turns
- Hoofdnaald fabrieksinstellingen: 4 toeren
- Stationair naald fabrieksinstellingen: 1 1/2 toeren
- Nadel für hohe Drehzahlen (Werkseinstellungen) 4 Umdrehungen
- Leerlauf Nadel (Werkseinstellungen) 1 1/2 Umdrehungen
- Réglage d'usine du pointeau principal: 4 tours
- Réglage d'usine de la vis de bas régime: 1 1/2 tours

- Idle adjustment screw
- Stationair toerental regelschroef
- Leerlaufdrehzahlschraube
- Réglage du ralenti

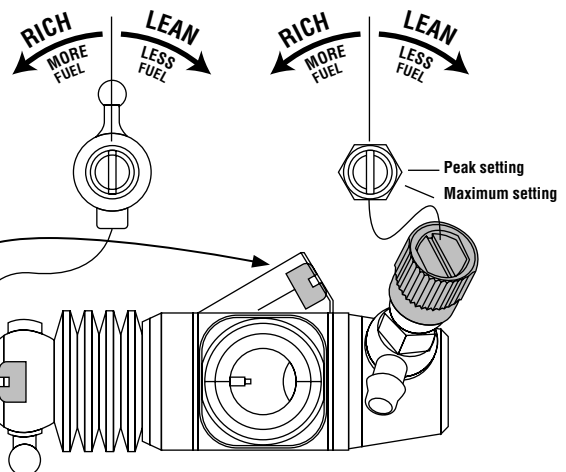

- A** • Safe range  
• Veilige zone  
• Sichere Strecke  
• Zone d'utilisation
- B** • Range for high speed performance  
• Zone voor hoge snelheidsprestaties  
• Strecke für Schnelleistung  
• Zone de haute performance
- C** • Range for low speed operation (Trial, climbing,...)  
• Zone voor lage snelheidsprestaties (Trial, traject met hindernissen,...)  
• Strecke für langsamen Betrieb (Trial, Hindernisstrecke,...)  
• Zone pour utilisation à vitesse lente (Trial, parcours d'obstacles,...)

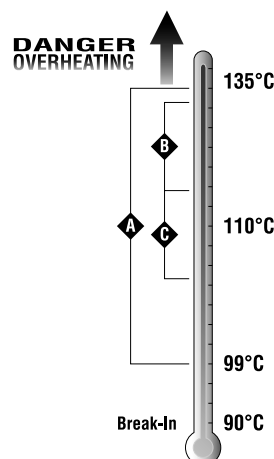

# RADIO



CE 0560

**PROTECH**

# FREQUENTIE / FREQUENCY / FREQUENCY / FREQUENZ

Frequentie    Kanaal    Frequentie    Toegelaten in volgende landen  
 Frequence    Canal    Frequence    Admis dans les pays suivants  
 Frequency    Channel    Frequency    Admitted in following countries  
 Frequenz    Kanal    Frequenz    Zugelassen in folgende Länder

			D	B	A	DK	F	I	L	N	NL	S	CH
27 MHz-Band													
	1	26,965											
	2	26,975											
	3	26,985											
	4	26,995	#	#	#	#		#	#	#	#	#	#
	5	27,005	#						#				
	6	27,015	#						#				
	7	27,025	#						#				
	8	27,035	#						#				
	9	27,045	#	#	#	#		#	#	#	#	#	#
	10	27,055	#						#				
	11	27,065	#						#				
	12	27,075	#						#				
	13	27,085	#						#				
	14	27,095	#	#	#	#		#	#		#		#
	15	27,105	#						#				
	16	27,115	#						#				
	17	27,125	#						#				
	18	27,135	#						#				
	19	27,145	#	#	#	#		#	#	#	#	#	#
	20	27,155	#						#				
	21	27,165	#						#				
	22	27,175	#						#				
	23	27,185	#						#				
	24	27,195	#	#	#	#		#	#		#	#	#
	25	27,205	#						#				
	26	27,215	#						#				
	27	27,225	#						#				
	28	27,235						#	#				
	29	27,245							#				
	30	27,255	#		#	#			#	#			
	31	27,265							#				
	32	27,275						#	#				
35 MHz-Band													
	61	35,010	#	#	#	#			#	#	#		
Band A	62	35,020	#	#	#	#			#	#	#		
	63	35,030	#	#	#	#			#	#	#	#	
	64	35,040	#	#	#	#			#	#	#	#	
	65	35,050	#	#	#	#			#	#	#	#	
	66	35,060	#	#	#	#			#	#	#	#	
	67	35,070	#	#	#	#			#	#	#	#	
	68	35,080	#	#	#	#			#	#	#	#	
	69	35,090	#	#	#	#			#	#	#	#	
	70	35,100	#	#	#	#			#	#	#	#	
	71	35,110	#	#	#	#			#	#	#	#	
	72	35,120	#	#	#	#			#	#	#	#	
	73	35,130	#	#	#	#			#	#	#	#	
	74	35,140	#	#	#	#			#	#	#	#	
	75	35,150	#	#	#	#			#	#	#	#	
	76	35,160	#	#	#	#			#	#	#	#	
	77	35,170	#	#	#	#			#	#	#	#	
	78	35,180	#	#	#	#			#	#	#	#	
	79	35,190	#	#	#	#			#	#	#	#	
	80	35,200	#	#	#	#			#	#	#	#	
Band B	182	35,820	#						#	#			
	183	35,830	#						#	#			
	184	35,840	#						#	#			
	185	35,850	#						#	#			
	186	35,860	#						#	#			
	187	35,870	#						#	#			
	188	35,880	#						#	#			
	189	35,890	#						#	#			
	190	35,900	#						#	#			
	191	35,910	#						#	#			

		D	B	A	DK	F	I	L	N	NL	S	CH
40 MHz-Band												
50	40,665	#	#	#	#			#	#	#	#	#
51	40,675	#	#	#	#			#	#	#	#	#
52	40,685	#	#	#	#			#	#	#	#	#
53	40,695	#	#	#	#			#	#	#	#	#
54	40,715	#						#		#	#	#
55	40,725	#						#		#	#	#
56	40,735	#						#		#	#	#
57	40,765	#						#			#	#
58	40,775	#						#			#	#
59	40,785	#						#			#	#
81	40,815	#						#			#	#
82	40,825	#						#			#	#
83	40,835	#						#			#	#
84	40,865	#						#			#	#
85	40,875	#						#			#	#
86	40,885	#						#			#	#
87	40,915	#						#			#	#
88	40,925	#						#			#	#
89	40,935	#						#			#	#
90	40,965	#						#			#	#
91	40,975	#						#			#	#
92	40,985	#						#			#	#

41 MHz-Band												
400	41,000					#						
401	41,010					#						
402	41,020					#						
403	41,030					#						
404	41,040					#						
405	41,050					#						
406	41,060					#						
407	41,070					#						
408	41,080					#						
409	41,090					#						
410	41,100					#						
411	41,110					#						
412	41,120					#						
413	41,130					#						
414	41,140					#						
415	41,150					#						
416	41,160					#						
417	41,170					#						
418	41,180					#						
419	41,190					#						
420	41,200					#						

72 MHz-Band												
200	72,000		#			#						
202	72,020		#			#						
204	72,040		#			#						
206	72,060		#			#						
208	72,080		#			#		#				
210	72,100		#			#						
212	72,120		#			#						
214	72,140		#			#						
216	72,160		#			#						
218	72,180		#			#						
220	72,200		#			#						
222	72,220		#			#						
224	72,240		#			#		#				
226	72,260		#			#						
228	72,280		#			#						
230	72,300		#			#						
232	72,320		#			#						
234	72,340		#			#						
236	72,360		#			#						
238	72,380		#			#						
240	72,400		#			#						
242	72,420		#			#						
244	72,440		#			#						
246	72,460		#			#						
248	72,480		#			#						
250	72,500		#			#						



**CE 0560** **This product is in accordance with/ce produit est conforme la/ Dit produkt is overeenkomstig****Richtlijnen - Directive - Richtlinie - Directive 1999/5/EG R&TTE**

- This product is destined for use in Europe. Use may be restricted by licence in some countries.
- Dit produkt is bestemd voor gebruik in Europa. Gebruik kan beperkt zijn door vergunningen in bepaalde landen.
- Ce produit est destiné pour emploi en Europe. L'emploi peut être limité par une autorisation dans certains pays.
- Dieses Produkt ist bestimmt für Gebrauch in Europa. Das Gebrauch kann eingeschränkt sein durch ein Erlaubniss in einige Länder.

**EC-Conformity Declaration**

For the following equipment:

**PISTOL TYPE 2 CH AM RADIO CONTROL SYSTEM**

(Product Name)

**GENX**

(Model Designation)

is herewith confirmed to comply with the requirements set out in the Council Directive on the Approximation of the Laws of the Member States relating to R&TTE Directive (99/5/EC). For the evaluation regarding the electromagnetic compatibility, the following standards were applied:

EN 300 220-3	September 2000	V1.1.1
ETS 300 683	June 1997	
EN 60950	August 1992	A1,A2,A3,A4,A11

The following importer/manufacture is responsible for this declaration:

PRO MODELS BVBA  
(Company Name, Importer)

CARDIJNLAAN 40  
B 2200 HERENTALS  
(Company Address, Importer)

Contact Person for this declaration

STEFAN ENGELN  
Name, Surname, Importer)

DIRECTOR  
(Position/Title)

(Legal Signature)

Person responsible for this declaration:

J.C.TSAI GEWISF Industrial Inc.  
(Name, Surname, Manufacturer)

VICE PRESIDENT  
(Position/Title)

(Legal Signature)

BELGIUM - HERENTALS 08-05-2001  
(Place) (Date)

Taiwan, R.O.C.  
(Place)

APR. 26. 2001  
(Date)

# ***All you need is inside our 300 pages full colour catalog***



**PROTECH® is a registered trademark  
Geelseweg 80 • B-2250 OLEN • Belgium  
Tel. +32 (0)14-25 92 83 • E-mail: [info@protech.be](mailto:info@protech.be)  
[www.protech.be](http://www.protech.be)**

**PROTECH®**